

# **Chapter 0**

## **General Manual Information**

---

---

# Chapter 1

## 1.1 General Description

---

### General Information

The OL400e, OL410e, and the OL410e/PS are compact Light Emitting Diode (LED) page printers. The printers utilize an LED head for the exposure method. Dry electrophotography is used as the development method. The print resolution is 300 x 300 dots per inch. The OL410e and the OL410e/PS (in PCL Mode) can print at 300 x 1200 dots per inch. The printers have a continuous print speed of up to 4 sheets per minute.

All three products include both a Centronics parallel interface and a 9-pin RS232 serial interface as standard features. The OL410e/PS includes an LocalTalk interface, which can only be used in PostScript mode. The printers have automatic interface switching capabilities, a power-saving standby mode, free-paper sizing (which allows printing on custom size paper), and graphic compression capabilities (for full-page business graphics).

The OL400e utilizes 512 Kbyte of standard Random Access Memory (RAM). An optional expansion memory board can be installed. Up to 4 Mbyte of RAM (in 1 Mbyte increments) can be installed on the expansion board, providing up to 4.5 Mbyte of total RAM in the OL400e.

The OL410e utilizes 2 Mbyte of standard Random Access Memory (RAM). The main controller board contains 1 Mbyte of RAM. The standard expanded memory board contains 1 Mbyte. An optional expansion memory board can be installed in place of the standard expanded memory board. The optional board contains 2 Mbyte of RAM. However, up to 4 Mbyte of RAM (in 1 Mbyte increments) can be installed, providing up to 5 Mbyte of total RAM in the OL410e.

The OL410e/PS utilizes 2 Mbyte of standard Random Access Memory (RAM). 1 Mbyte is on the main control board. 1 Mbyte is on the PostScript Board. The PostScript board will accept and additional 3 Mbytes of RAM, providing up to 5 Mbyte of total RAM in the OL410e/PS.

A universal / letter cassette is included with each printer. Legal, executive, and A4 trays are available.

The printers will print on a variety of paper types, labels, and transparencies.

---

## 1.2 Product Specifications

---

### 1.2 PRODUCT SPECIFICATIONS

#### 1.2.01 Print Specifications

Exposure Method  
Stationary LED Head  
Development Method  
Dry Electrophotography

#### 1.2.02 Print Speed

Continuous Print  
4 sheets per minute  
Warm-up Time  
Approximately 60 seconds with standard memory  
Approximately 90 seconds with the memory expansion board installed

#### 1.2.03 Print Resolution

Standard Printing Mode  
300 x 300 dots/inch  
Enhanced Printing Mode(OL410e and OL410e/PS in HP LaserJet III mode)  
300 x 1200 dots/inch (600 dpi Class Printing)

#### 1.2.04 Symbol Sets

40 Symbol Sets

#### 1.2.05 Paper Feed Method

Automatic Feed  
Manual Feed

#### 1.2.06 Paper Delivery Methods

Face down  
Face up

#### 1.2.07 Interface Capabilities

OL400e/OL410e Interfaces  
Centronics Parallel Interface  
RS232 Serial Interface  
OL410e/PS Interfaces (with Auto-switching)  
RS232 Serial Interface  
Centronics Parallel Interface  
LocalTalk (PostScript only)

#### 1.2.08 Emulations

OL400e  
HP LaserJet IIP  
OL410e  
HP LaserJet III (HP PCL 5)  
OL410e/PS  
HP LaserJet III (HP PCL 5)  
Adobe PostScript Level 2

NOTE: When operating under the DOS environment, the OL410e/PS supports auto-emulation switching by means of the Oki-Switch software, which is included with the printer.

#### 1.2.09 Available Fonts

The OL400e and OL410e printers contain four resident bit mapped typefaces which can be printed in both landscape and portrait orientations.

- Courier
- Swiss
- Line (LN) Printer
- Dutch

The OL410e contains three scalable typefaces, in addition to the four bitmapped typefaces.

- CG Times
- Univers
- Courier

The OL410e/PS contains the following fonts.

- Resident Fonts
- Adobe PostScript
- 35 (Type 1 Fonts)

2 (Multiple Master Fonts) - for use with Adobe ATM 3.0 and Adobe Acrobat

- PCL5
- 12 Scalable Fonts
- Bit mapped Fonts/Typefaces
- 2 Line Printer Fonts
- USPS Barcode Fonts

The OL400e and OL410e use twenty bit mapped fonts from the four typefaces.

Courier		10 cpi
Courier	Bold	10 cpi
Courier	Italic	10 cpi
Courier		12 cpi
Courier	Bold	12 cpi
Courier	Italic	12 cpi
LN Printer		16.67 cpi
Swiss	Bold	Proportional (B)
Swiss	Bold	Proportional (F)
Dutch		Proportional (B)
Dutch	Bold	Proportional (B)
Dutch	Italic	Proportional (B)
Dutch		Compressed (B)
Dutch	Bold	Compressed (B)
Dutch	Italic	Compressed (B)
Dutch		Proportional (F)
Dutch	Bold	Proportional (F)
Dutch	Italic	Proportional (F)
Dutch		Proportional (B)
Dutch		Compressed (B)

NOTE: cpi = Characters Per Inch

---

## 1.3 Paper Specifications

---

### 1.3 PAPER SPECIFICATIONS

CAUTION: All paper (all types) should be designed for xerographic printing.

Envelopes, labels, and transparencies should only be fed from the top paper tray or manually. Use the face-up paper ejection path. DO NOT use the optional second paper feed mechanism for these items.

#### 1.3.01 Paper Types

##### Letter

Size: 8.5" x 11" (216 mm x 279 mm)

Feed: Automatic or Manual

##### Weight

Minimum: 16 lbs. (60 g / m<sup>2</sup>)

Maximum: 24 lbs. (90 g / m<sup>2</sup>)

Recommended: 20 lbs. (75 g / m<sup>2</sup>)

##### Legal

Size: 8.5" x 13" (216 mm x 330 mm) 8.5" x 14" (216 mm x 356 mm)

Feed: Automatic (with optional paper tray)

##### Weight

Minimum: 16 lbs. (60 g / m<sup>2</sup>)

Maximum: 24 lbs. (90 g / m<sup>2</sup>)

Recommended: 20 lbs. (75 g / m<sup>2</sup>)

##### Executive

Size: 7.25" x 10.5" (184 mm x 267 mm)

Feed: Automatic (with optional paper tray) or Manual

##### Weight

Minimum: 16 lbs. (60 g / m<sup>2</sup>)

Maximum: 24 lbs. (90 g / m<sup>2</sup>)

Recommended: 20 lbs. (75 g / m<sup>2</sup>)

##### A4

Size: 8.27" x 11.69" (210 mm x 297 mm)

Feed: Automatic (with optional paper tray)

##### Weight

Minimum: 16 lbs. (60 g / m<sup>2</sup>)

Maximum: 24 lbs. (90 g / m<sup>2</sup>)

Recommended: 20 lbs. (75 g / m<sup>2</sup>)

##### A5

Size: 5.83" x 8.27" (148 mm x 210 mm)

Feed: Automatic (with optional paper tray)

##### Weight

Minimum: 16 lbs. (60 g / m<sup>2</sup>)

Maximum: 24 lbs. (90 g / m<sup>2</sup>)

Recommended: 20 lbs. (75 g / m2)

A6

Size: 4.13" x 5.83" (105 mm x 148 mm)  
Feed: Automatic (with optional paper tray)

Weight  
Minimum: 16 lbs. (60 g / m2)  
Maximum: 24 lbs. (90 g / m2)  
Recommended: 20 lbs. (75 g / m2)

B6

Size: 7.17" x 10.12" (182 mm x 257 mm)  
Feed: Automatic (with optional paper tray)

Weight  
Minimum: 16 lbs. (60 g / m2)  
Maximum: 24 lbs. (90 g / m2)  
Recommended: 20 lbs. (75 g / m2)

Envelope

Size  
Minimum: 3.5" x 7.5" (89 mm x 191 mm)  
Maximum: 7.2" x 10.1" (183 mm x 257 mm)  
Feed: Automatic (with optional paper tray) or Manual

Weight  
Minimum: 16 lbs. (60 g / m2)  
Maximum: 24 lbs. (90 g / m2)  
Recommended: 20 lbs. (75 g / m2)

Labels

Manual feed / Face up delivery only  
Use labels designed specifically for xerographic printing

Transparencies

Manual feed / Face up delivery only  
Must be able to withstand the heat of the fusing process

### **1.3.02 Free Paper Size**

The Free Paper Size menu feature allows the end user to print on custom size paper without a paper size error.

Normally, if the paper is loaded in the paper tray is NOT the same size selected in the software, a PAPER SIZE error will be displayed when a print job is sent. Enabling the Free Paper Size menu feature will override this operation.

Free Paper Size Dimensions

Width  
Size: 3.4" x 8.5" (86.4 mm x 216 mm)

Length  
Size: 5.5" x 14" (140 mm x 355.6 mm)

Feed  
Automatic (with optional paper tray)

## Manual

### Weight

Minimum: 16 lbs. (60 g / m<sup>2</sup>)

Maximum: 24 lbs. (90 g / m<sup>2</sup>)

Recommended: 20 lbs. (75 g / m<sup>2</sup>)

### **To enable Free Paper Size, follow this procedure.**

- Place the printer OFF-LINE.
  - Press LAST / Paper Size for two seconds.
  - Press NEXT + repeatedly until FREE is displayed on the operator panel.
  - Press ENTER to select FREE as the default setting.
  - Press ON-LINE to exit the menu.
  - Place the custom size paper stock in Tray 1, the Manual Feed Tray, Tray 2, or the Multi-Purpose Feeder.
  - Run the print job.
-

## 1.4 Physical Specifications

---

### 1.4 PHYSICAL SPECIFICATIONS

1.4.01 Outside Dimensions  
Width: 12.6 inches (320 mm)  
Height: 6.3 inches (160 mm)  
Depth: 14.17 inches (360 mm)

1.4.02 Printer Weight  
24 lbs. (11 kg)  
1.4.03 LED Array

1.4.03 LED Array  
Number of LED Elements: 2560

---



## 1.5 Power Requirements

---

### 1.5 POWER REQUIREMENTS

- 1.5.01 Input Power
    - 120 VAC + 5.5% - 15%
    - 220/240 VAC +/- 10%
  
  - 1.5.02 Power Consumption
    - Peak
      - Approximately 600 Watts
    - Operation (typical)
      - Approximately 80 Watts
    - Idle
      - Approximately 40 Watts
    - Power Save
      - Approximately 15 Watts
-

## 1.6 Environmental Conditions

---

### 1.6 ENVIRONMENTAL CONDITIONS

#### 1.6.01 Ambient Temperature

Operation

50 to 90 degrees Fahrenheit  
10 to 32 degrees Celsius

Storage

14 to 110 degrees Fahrenheit  
-10 to 43 degrees Celsius

#### 1.6.02 Printer Noise Level

Operation

50 dBA (A) or less

Standby

45 dBA (A) or less

---

## 1.8 Options

---

### 1.8 OPTIONS

#### 1.8.01 Memory Expansion

##### OL400e

Expansion RAM Board: contains 1 Mbyte. Can be expanded up to 4.5 Mbyte in 1 Mbyte increments

##### OL410e

Expansion RAM Board: Contains 2 Mbyte. Can be expanded up to 5 Mbyte in 1 Mbyte increments

##### OL410e/PS

Resident RAM - 2 MByte  
Optional RAM - 3 MByte (in 1 Mbyte increments)  
Maximum RAM - 5 Mbyte

#### 1.8.02 Font Cards

Bit mapped (OL400e and OL410e)

OKIPRO 65  
Bar Codes Plus  
MICRO DOCS  
Tax

Scalable (OL410e and OL410e/PS in PCL5 emulation)

Distinctive Documents  
Perfect Presentations  
Wordperfect II Scalable

#### 1.8.03 Paper Trays

100 Sheet Letter Tray  
100 Sheet Legal Tray

---

## 1.9 Consumables

---

### 1.9 Consumables

#### 1.9.01 Image Drum Cartridge Kit

Contents  
Image Drum Cartridge

#### 1.9.02 Toner Cartridge Kit

Contents  
Toner Cartridge  
LED Lens Cleaner  
Toxicity  
No carcinogens are contained.

---

## 1.10 Memory Specifications

---

### 1.10 Memory Specifications

#### 1.10.01 ROM

Main Controller Program ROM

OL400e

512 Kbyte

OL410e

1 Mbyte

#### 1.10.02 RAM

OL400e

Standard: 512 Kbyte

Expansion: Up to 4.5 Mbyte (in 1 Mbyte increments)

OL410e

Standard: 2 Mbyte (1 Mbyte on the main controller  
and 1 Mbyte on the expanded memory board)

Expansion (on the expansion memory board, which replaces the  
1 Mbyte expanded memory board)

Up to 5 Mbyte (in 1 Mbyte increments)

OL410e/PS

Standard - 2 MByte (1 Mbyte on the main controller and 1 Mbyte  
on the PostScript board)

Expansion - 3 MByte (in 1 Mbyte increments) on the PostScript board

Maximum RAM - 5 Mbyte

#### 1.10.03 EEPROM

NOTE: EEPROM = Electrically Erasable Programmable Read Only Memory

Main Controller EEPROM

1024 x 1 bit serial input/output

---

## 1.11 Reliability Specifications

---

### 1.11 Reliability Specifications

#### 1.11.01 Mean Pages Between Failure (MPBF)

Approximately 24,000 pages

#### 1.11.02 Mean Time To Repair (MTTR)

Approximately 20 minutes

#### 1.11.03 Estimated Toner Cartridge Life

Approximately 2,000 pages at 5% density

#### 1.11.04 Image Drum Life

Approximately 20,000 pages: Continuous print at 5% density

Approximately 18,000 pages: at 7 pages per print job

#### 1.11.05 Printer Duty Cycle

Approximately 6,000 pages per month

---

## 2.1 Printer Overview

---

### 2.1 PRINTER OVERVIEW

#### 2.1.01 General Information

This section describes the operation of the product in the order listed below.

- Control Process
- Mechanical Operation
- Printing Process
- Sensors and Switches

---

## 2.2 Control Process

### 2.2 CONTROL PROCESS

#### 2.2.01 General Information

The control process involves regulating the reception of data from the host system interface, receiving data and commands from the host system, and generating bit-image data. The control process also includes sending data and commands to the print engine where the print process is performed.

The control process is performed by the following hardware components.

- Main Controller Board
- Expanded RAM Board (OL410e ONLY)
- Expansion RAM Board Option
- Font Card Option

#### Configuration Diagram

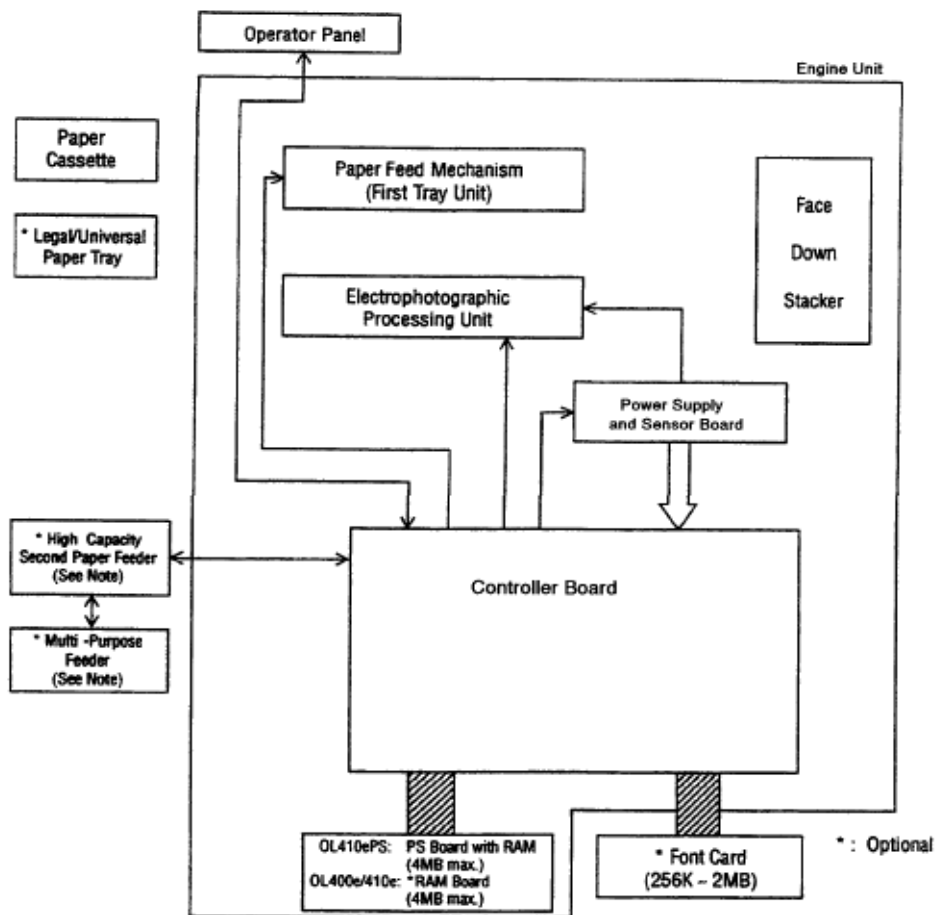



## 2.2.02 Block Diagrams 400E

### 2.2.02 Block Diagrams

OL400e

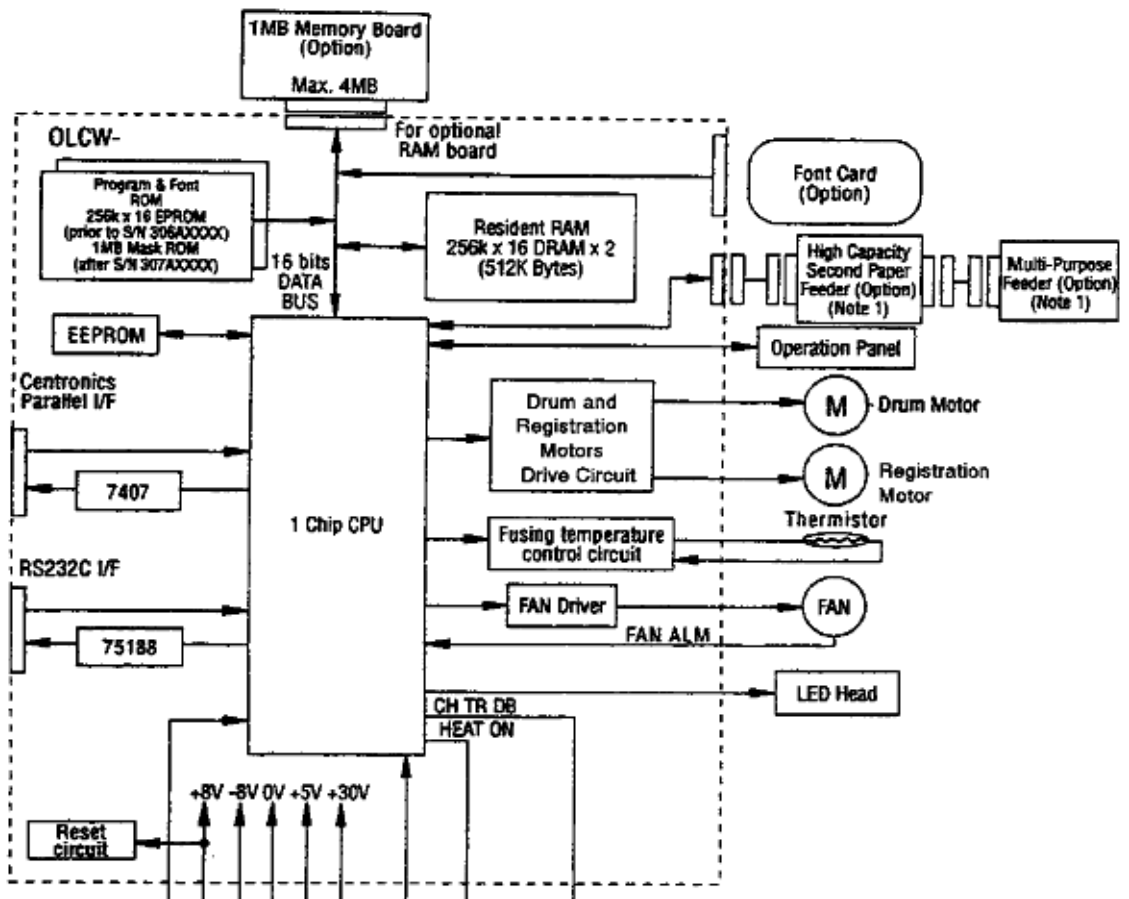

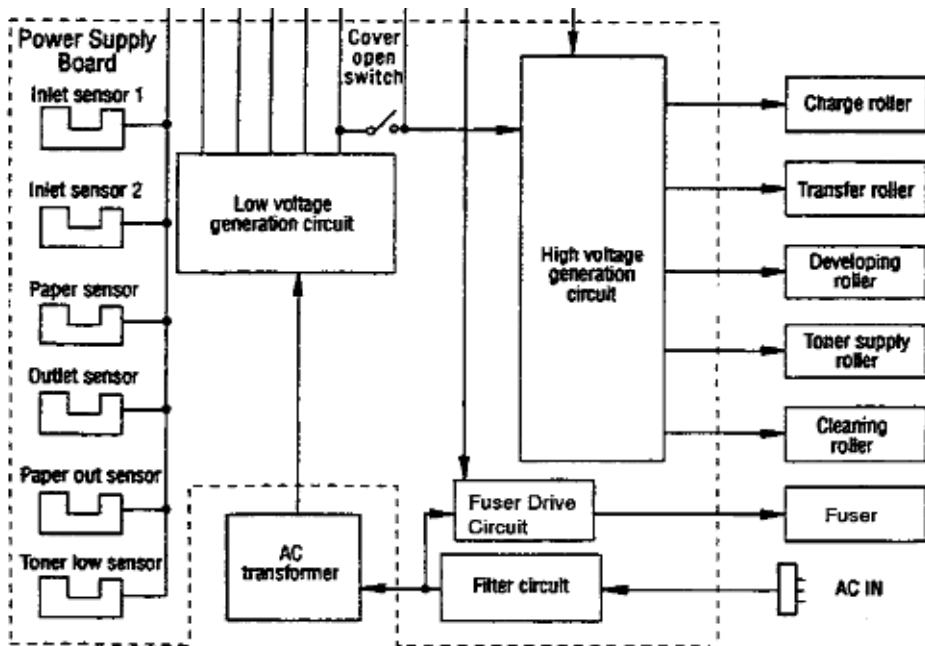

**Note 1:** These options are available for units with Serial Numbers 307AXXXXX and up.

## 2.2.02 Block Diagrams 410E

### 2.2.02 Block Diagrams

OL410e

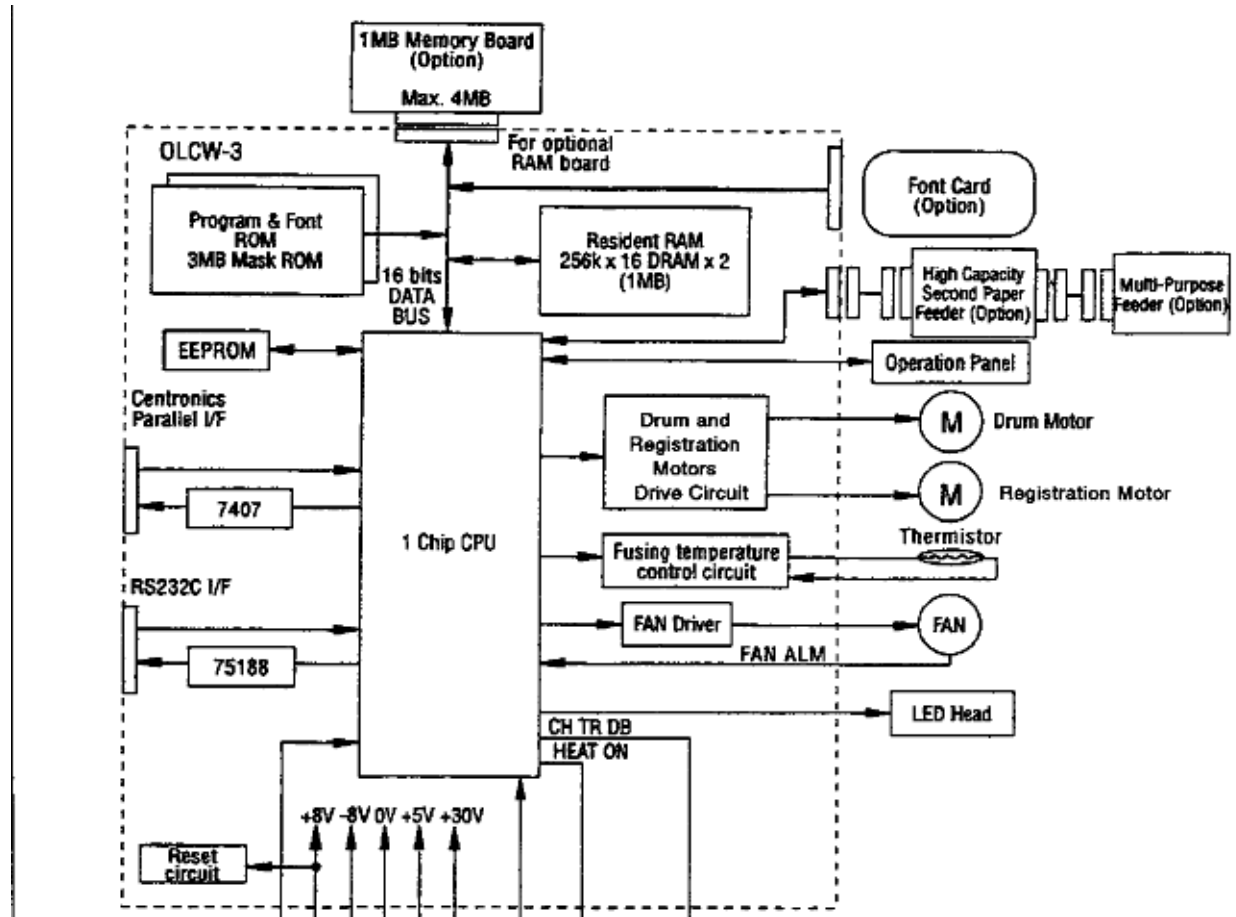

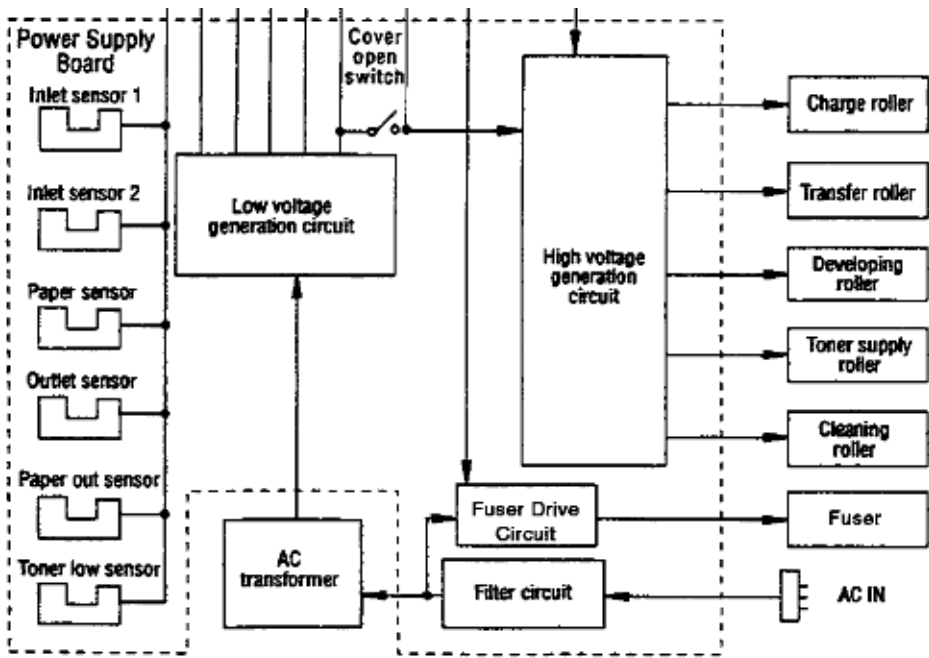

## 2.2.02 Block Diagrams 410E/PS

### 2.2.02 Block Diagrams

#### OL410eps

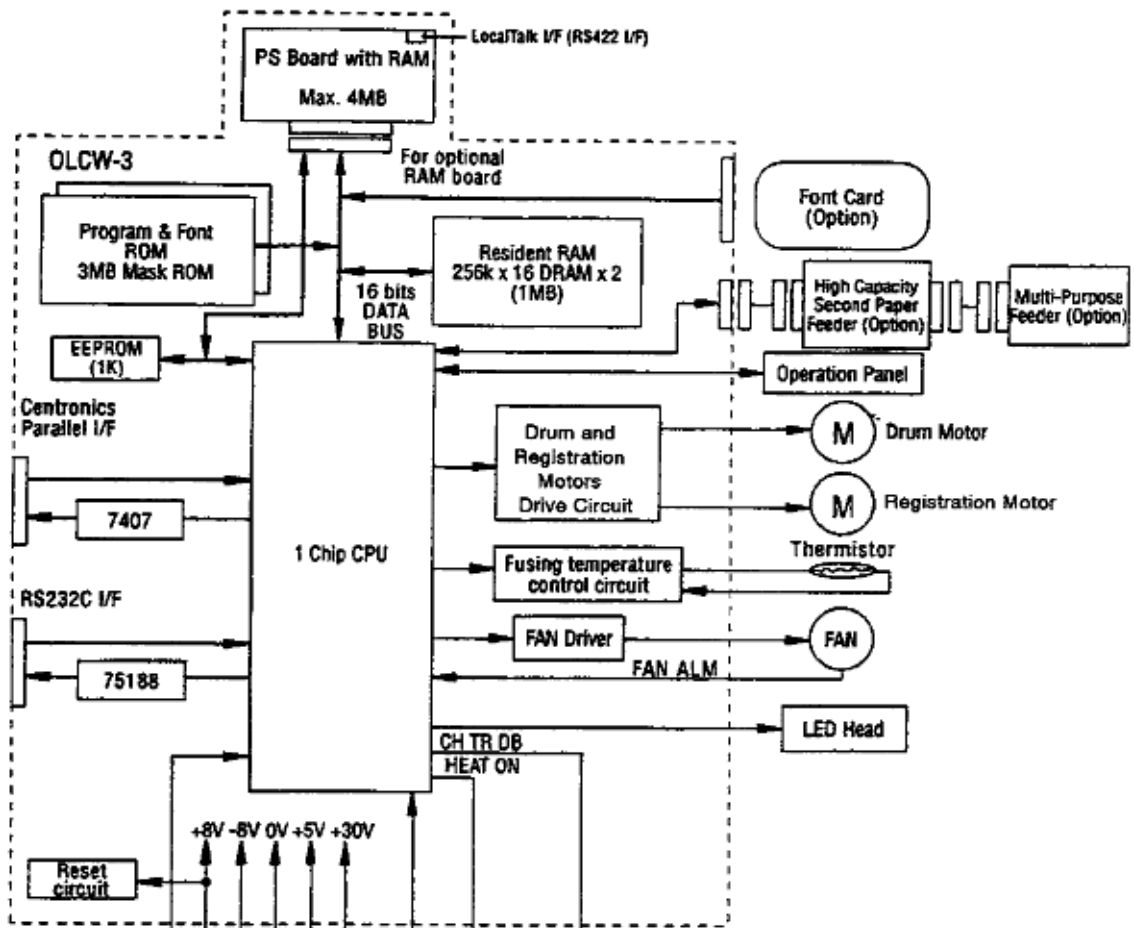

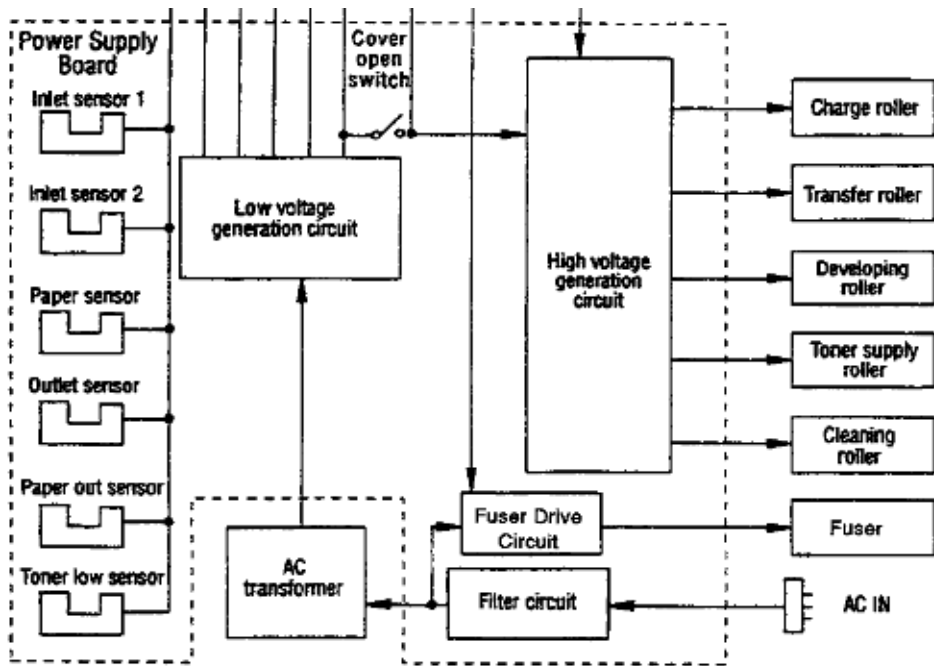

## 2.2.03 Main Controller Board (OLCW) Overview

---

### 2.2.03 Main Controller Board

#### Overview

The principal components of the main controller board are listed below.

- 16 Mhz Oscillator
- ASIC (with a built-in RISC microprocessor)
- PROM (contains printer control program)
- ROM (contains the bit-mapped fonts)
- EEPROM
- Dynamic RAM (DRAM)

OL400e

512 Kbyte

OL410e

1 Mbyte with an additional 1 Mbyte contained on the Expanded RAM Board

OL410e

1 Mbyte with an additional 1 Mbyte contained on the PostScript Board

Driver Circuitry

RS232 Serial Interface Port

Centronics Parallel Interface Port

Both the print engine functions and the control functions are integrated on the main controller board. Most of the logic needed to perform print engine functions and control functions is integrated internally in the microprocessor.

---

# Main Controller Board Functions

---

## Main Controller Board Functions

### General Information

The functions of the main controller board are listed below.

- Reception Control..... (📄)
  - Command Analysis Processing..... (📄)
  - Font Processing..... (📄)
  - Buffer Read Operation..... (📄)
  - Engine Control..... (📄)
    - Operation Panel Control..... (📄)
    - Operation Panel Functions..... (📄)
  - Sensor Control..... (📄)
  - Print Operation..... (📄)
  - Electrophotographic Processing Action..... (📄)
  - LED Array Operation..... (📄)
  - Fuser Lamp Operation..... (📄)
  - Registration Motor Operation..... (📄)
  - Drum Motor Operation..... (📄)
  - DC Fan Operation
-



## Reception Control

---

### Main Controller Board Reception Control

As data is received from the host system, the CPU sets the BUSY-P signal to ON and reads the parallel data lines (DATA 1 - DATA 8). The I-PRIME signal (Enable/Disable) of the parallel interface port can be specified through the menu.

The serial data from the host system is received by the built-in serial controller of the microprocessor.

Both the parallel and serial interface ports can receive data. The port that receives data first will be activated.

---

# Command Analysis Processing

---

## Main Controller Board Command Analysis Processing

- The OL400e emulates the HP LaserJet Series IIP.
  - The OL410e emulates the HP LaserJet Series III.
  - The OL410e/PS emulates the HP LaserJet Series III and also contains a PostScript (Level 2) Interpreter
-

# Font Processing

---

## Main Controller Board Font Processing

### OL400e

- Bit mapped fonts are available for the HP LaserJet Series IIP emulation.

### OL410e

- Bit mapped and scalable fonts are available for the HP LaserJet Series III emulation.

### OL410e/PS

- Scalable fonts are available for the HP LaserJet Series III emulation.
  - PostScript Fonts are contained on the PostScript Board.
-

## **Main Controller Board Buffer Read Operation**

---

### **Main Controller Board Buffer Read Operation**

Bit images written in the raster buffer (registers) are converted to serial data. The contents of the registers are transferred to the engine control section of the microprocessor (MPU) on the main controller board.

---

# Engine Control Functions

---

## Main Controller Board Engine Control Functions

Engine control functions are executed when the CPU receives a print request signal.

---

# Operation Panel Control

---

## Main Controller Board Operation Panel Control

### General Information

The operation panel consists of the following circuits.

- MPU Interface Integrated Circuit
  - LCD Control Driver
  - LCD Display
  - LED
  - Operation Panel Sheet
  - Contact Switches (There are eight contact switches).
-

## Operation Panel Functions

---

### Main Controller Board Operation Panel Functions

The operation panel LCD displays the printer's operational status and error messages. The operation panel is also used to modify the printer menu.

The operation panel is connected to the main controller board through connector CN1 of the contact switch board and CN5 of the main controller board.

The LCD control driver board is connected to the contact switch board. The connector on the contact switch board is CN2, and the connector on the control drive board is CN3.

The operation panel is controlled by the CPU of the main controller board. The LSI chip on the contact switch board is connected to a clock-synchronous serial port of the CPU. This port controls the switch data input, LED data output, and LCD data. The CPU sends a 2-byte (16-bit) command to the LSI. Upon receiving a command from the CPU, the LSI returns a 2-byte command response to the CPU.

---

# Sensor Control & Location Diagrams

## Sensor Control & Location Diagrams

### General Information

There are six sensors in the printer.

- Inlet Sensor 1..... ( )
- Inlet Sensor 2..... ( )
- Inlet Sensor 3..... ( ) *(also known as the Paper Sensor)*
- Outlet Sensor..... ( )
- Paper Supply Sensor.... ( )
- Toner Sensor..... ( )

The same part is used in three locations for the three inlet sensors.

## Sensor Location Diagrams

### Top View

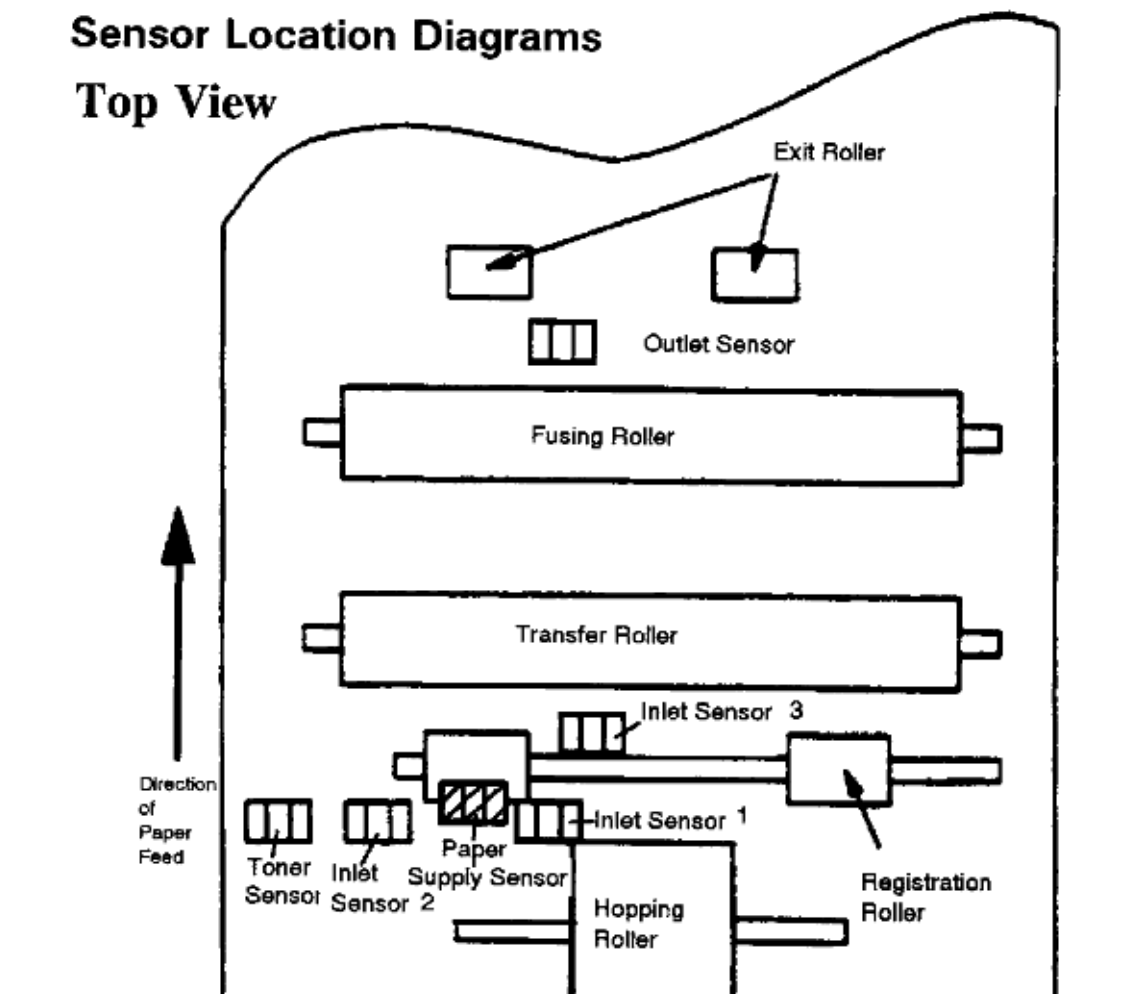



## Side View

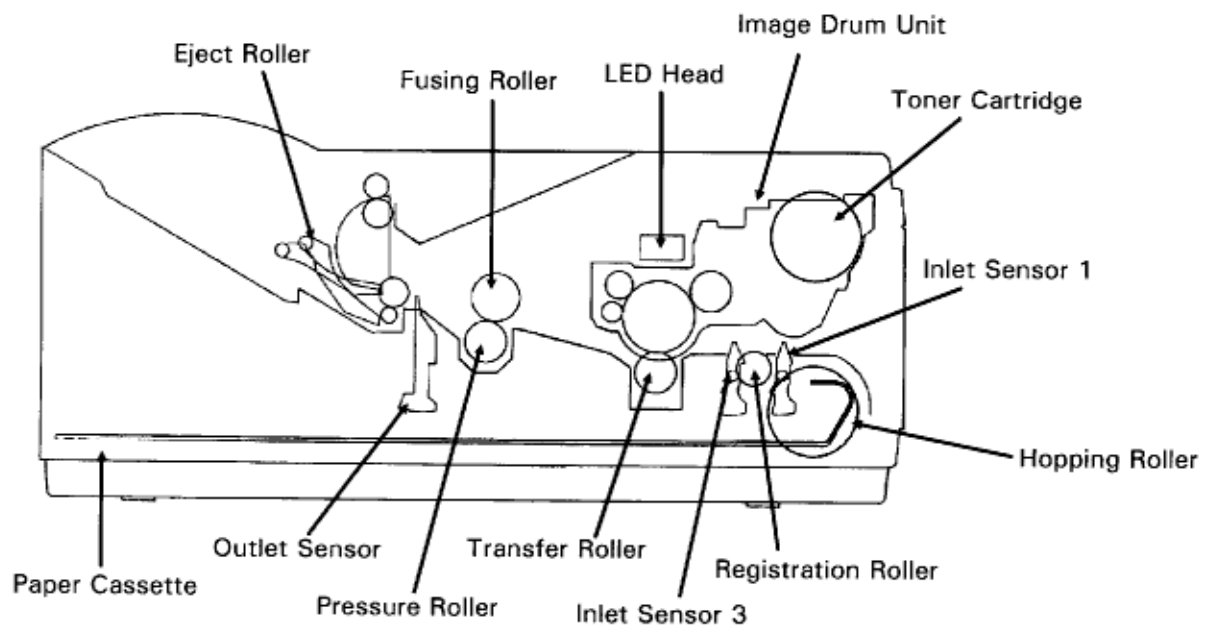

## Inlet Sensor 1

---

### Inlet Sensor 1

Inlet sensor 1 detects the leading edge of the paper and regulates the timing of switching from the hopping operation to the feeding operation.

This sensor also controls the timing of the paper feed process and the paper size according to the paper detection time and running time.

Refer to Sensor Diagram () for exact location.

---

## Inlet Sensor 2

---

### Inlet Sensor 2

Inlet sensor 2 detects the form width.

Refer to Sensor Diagram () for exact location.

---

## Inlet Sensor 3 / Paper Sensor

---

### Inlet Sensor 3 / Paper Sensor

Inlet sensor 3 detects the leading edge of the paper and controls the timing of the paper feed process. This sensor is also referred to as the paper sensor.

Refer to Sensor Diagram () for exact location.

---

## Outlet Sensor

---

### Outlet Sensor

The outlet sensor controls the paper feed and size based on the time the sensor detects the paper and the time of passage of the paper.

Refer to Sensor Diagram () for exact location.

---

## Paper Supply Sensor

---

### Paper Supply Sensor

The paper end sensor detects an out-of-paper condition.

Refer to Sensor Diagram () for exact location.

---

## Toner Sensor

---

### Toner Sensor

The toner sensor detects a low-toner condition.

Refer to Sensor Diagram () for exact location.

---

## Print Operation

---

### Print Operation

Both the control function (data reception and bit-image data generation) and the print engine function (LED head, registration motor, and drum motor) are integrated. Both functions are controlled by the main controller board. The peripheral logic is integrated into one chip, an ASIC microcomputer (RISC-based microprocessor) chip.

Data is received through either the Centronics parallel interface or the RS232 serial interface. These two interfaces are located on the main control board.

The LocalTalk interface is located on the PostScript Board.

The data is then stored in the receive buffer. The data is transferred from the receive buffer to a processing section of the main controller. In this processing section, control codes and printing codes are assigned. Once the font is determined, the data is written to the page buffer.

The microprocessor then executes the print routine. The data is extracted from the page buffer, synchronized to the printing operation, and written to the band buffer. While performing the engine functions, the microprocessor sends the data from the band buffer to the LED array head.

---



## **2.2.04 Expanded Ram Board(410E Only)**

---

### **2.2.04 Expanded RAM Board(OL410e Only)**

The expanded RAM board contains 1 Mbyte of RAM and along with the 1 Mbyte of RAM on the main controller board, increases the standard RAM capacity to 2 Mbyte. The RAM capacity is identified during power-ON. It can be verified by requesting a MENU PRINT operation.

---

## **2.2.05 Expansion Ram Board(400E)**

---

### **2.2.05 Expansion RAM Board(OL400e)**

The expansion RAM board can contain up to 4 Mbyte of RAM in 1 Mbyte increments. This board can increase the OL400e RAM capacity up to 4.5 Mbyte. The RAM capacity is identified during power-ON. It can be verified by requesting a MENU PRINT operation.

---

## **2.2.06 Expansion Ram Board(410E)**

---

### **2.2.06 Expansion RAM Board(OL410e)**

The expansion RAM board is an option installed in place of the expanded RAM board. This board can contain up to 4 Mbyte of RAM in 1 Mbyte increments. This board can increase the OL410e RAM capacity up to 5 Megabyte. The RAM capacity is identified during power-ON. It can be verified by requesting a MENU PRINT operation.

---

## 2.2.07 Font Cards

---

### 2.2.07 Font Cards

An optional font card can be used with the printer. The printer must be OFF-LINE (the READY lamp is OFF) when the card is either inserted or removed. If the font card is inserted or removed while the printer is ON-LINE (the READY lamp is ON), a CARD REMOVED ON-LINE message will appear on the operator panel display.

---

## 2.2.08 Postscript Board

---

### 2.2.08 PostScript Board

The PostScript Board contains the LocalTalk interface, a program ROM and Font Rom (2 MB each), 1 MByte of Dynamic RAM, and a 4 KBit EEPROM. Sockets are provided for an additional 3 Mbyte of DRAM.

---

## 2.3.01 Basic Principals - Electrostatic Printing

### 2.3.01 Basic Principals - Electrostatic Printing

A -1.3 Kvdc charge is placed on the charge roller. The charge roller is in direct contact with the surface of the image drum. The printer engine section enables the LED array in conformance with the data received from the host via the interface on the main controller board. Once the charged drum is exposed to this light, an electrostatic image is formed on the drum surface. This latent image is developed with toner.

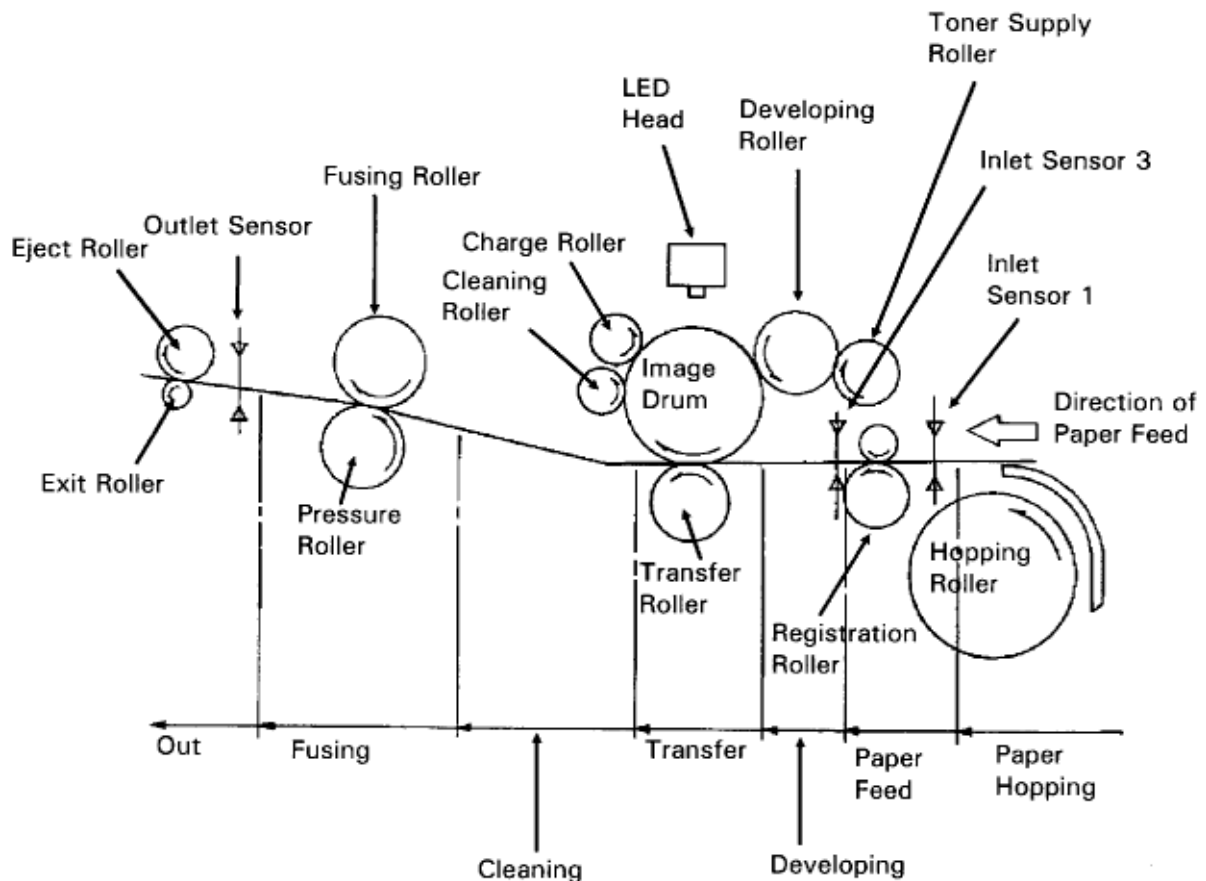

#### Charging

The surface of the image drum is uniformly negatively charged by the application of a negative charge to the charge roller.

#### Exposure

Light emitted from the LED head irradiates the negatively charged surface of the image drum. The electrostatic potential of the irradiated part of the image drum surface is lowered, so that an electrostatic latent image associated with the print image is formed.

#### Developing

When the negatively charged toner is brought into contact with the image drum surface, it is attracted to the electrostatic latent image by static electricity, making the latent image visible. At the same time, the residual toner on the image drum is attracted to the developing roller by static electricity.

#### Transfer

Paper is placed over the image drum surface. A positive charge (opposite in polarity to the toner) is applied to the reverse side of the paper by the transfer roller. The toner is attracted by the positive charge. The image formed on the image drum is transferred to the paper.

**Cleaning**

The toner remaining on the image drum after transfer is temporarily attracted to the cleaning roller by static electricity. This residual toner is accumulated in the image drum cartridge until the drum is replaced.

**Fusing**

The toner image transferred to the paper is fused to the paper by heat and pressure.

---

## 2.3.02 Engine Functions

---

### 2.3.02 Engine Functions

The engine control section of the microprocessor on the main controller board enables the fuser lamp and activates the preliminary print circuits. Upon completion of the preliminary print functions, the engine control section enables the LED array in conformance with the signals received from the host, and commands output from the control section of the CPU. The LED illuminates, leaving a latent image on the photosensitive drum. The engine control section also controls paper feed, paper transfer and the electrophotographic printing process.

---



## 2.3.03 Eeprom Operation

---

### 2.3.03 EEPROM Operation

The 1024 x 1 bit Electrically Erasable Programmable Read-Only-Memory (EEPROM) is loaded with the data listed below.

- Menu Data
  - Various Counter Data
  - LED Head Drive Time
  - Print Start Position
  - Paper Feed Duration
-

## 2.3.04 Power Supply Board

---

### 2.3.04 Power Supply Board

The power supply board consists of an AC filter circuit, a low-voltage power supply circuit, a high-voltage power supply circuit, a fuser drive circuit and photosensors.

#### Low-Voltage Power Supply Circuit

The following voltages are generated by the low-voltage power supply circuit.

- + 5 vdc: Logic circuit supply voltage
- + 38 vdc: Motor / fan drive voltage and source voltage for the high-voltage supply
- + 8 vdc: RS232 line voltage
- 8 vdc: RS232 line voltage and analog circuit voltage

#### High-Voltage Power Supply Circuit

This circuit uses the + 38 vdc to generate voltages for the electrophotographic process. The control sequence for enabling these voltages is issued by the main controller board. When the cover-open state is detected, the + 38 vdc is turned off. Turning the +38 vdc off disables all high-voltage outputs. The high-voltage power circuit generates the voltages listed below.

- 1.3 Kvdc: applied to the charging roller
  - 300 vdc: applied to the developing roller
  - 450 vdc: applied to the toner supply roller
  - + 1.6 Kvdc: applied to the transfer roller
  - + 500 vdc: applied to the cleaning roller
-

## 2.3.05 Fusing Unit

---

### 2.3.05 Fusing Unit

The fusing unit consists of a halogen lamp, a fusing roller, a thermistor and a thermostat. An AC voltage from the power supply board is applied to the halogen lamp under the control of the HEAT ON signal from the main controller board. This AC voltage is applied to the 400 watt halogen lamp. The main controller board controls the fusing roller temperature via the thermistor, and regulates the fusing roller temperature at 150 degrees Celsius by switching the lamp ON/OFF. If the roller temperature rises abnormally, the thermostat in the fusing unit will cut the AC voltage supply OFF.

---

## 2.3.06 Registration Motor

---

### 2.3.06 Registration Motor

The registration motor is a DC stepping motor (48 steps/rotation). This motor drives the hopping roller and the registration roller via two one-way clutches. The direction that the motor turns determines which clutch is activated.

---

## **2.3.07 Drum Motor**

---

### **2.3.07 Drum Motor**

The drum motor is a DC stepping motor (48 steps/rotation).  
This motor is the main drive motor of the printer.

---

## **2.3.08 LED Head**

---

### **2.3.08 LED Head**

Image data for each dot line is received by shift registers and latch registers.

The 2,560 LEDs are activated to radiate the image data onto the image drum.

---

## **\*\*2.4 Printing Process General Information**

---

### **2.4.01 PRINTING PROCESS General Information**

Hopping and feeding are controlled by a single registration motor.

Turning the registration motor in the "A" direction drives the hopping roller.

Turning the registration motor in the "B" direction drives the registration roller.

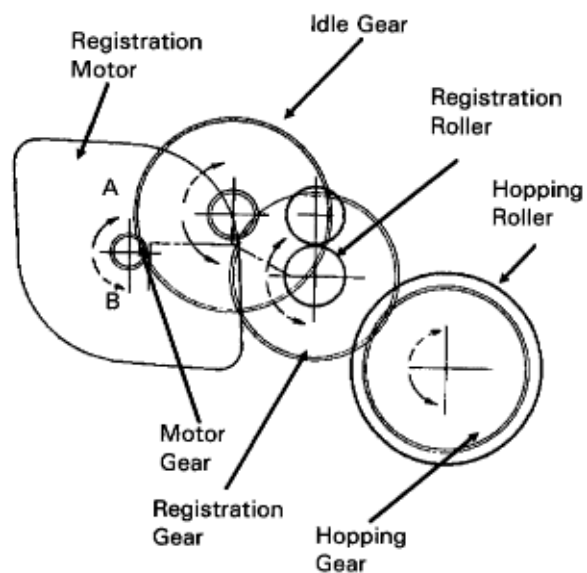

The registration gear and hopping gear contain one-way bearings. Turning each of these gears in the reverse direction will NOT turn the corresponding roller.

The following is too big!!!!

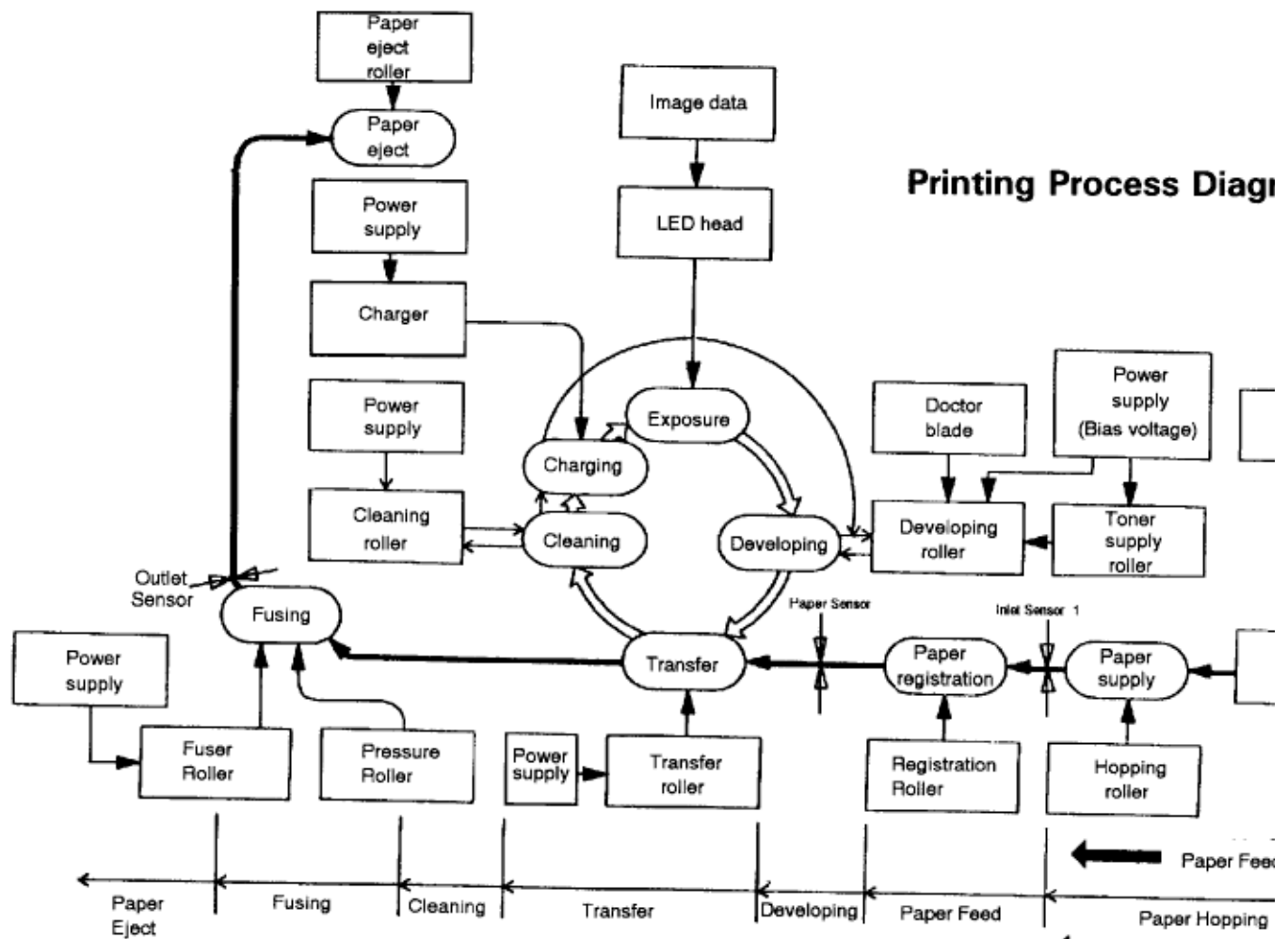



## 2.4.02 Hopping

---

### 2.4.02 Hopping

Hopping loads paper from the paper cassette.

During the hopping operation, the registration motor turns in a clockwise direction. This motor drives the hopping roller, which in turn advances the paper until the inlet sensor 1 switches ON. The registration gear turns, but the one-way bearing does not allow the registration roller to turn.

After inlet sensor 1 switches ON, the paper is advanced a predetermined length (until the paper reaches the registration roller).

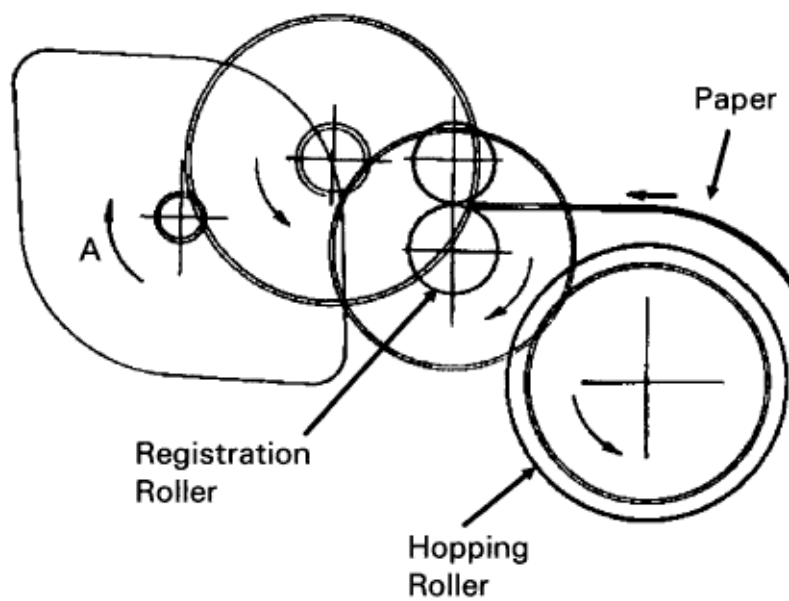

## 2.4.03 Feeding

---

### 2.4.03 Feeding

Feeding transports paper through the printer.

After the completion of hopping, the registration motor turns in a counter-clockwise direction. This counter-clockwise motion drives the registration roller and advances the paper. The hopping gear turns, but the one-way bearing does not allow the hopping roller to turn.

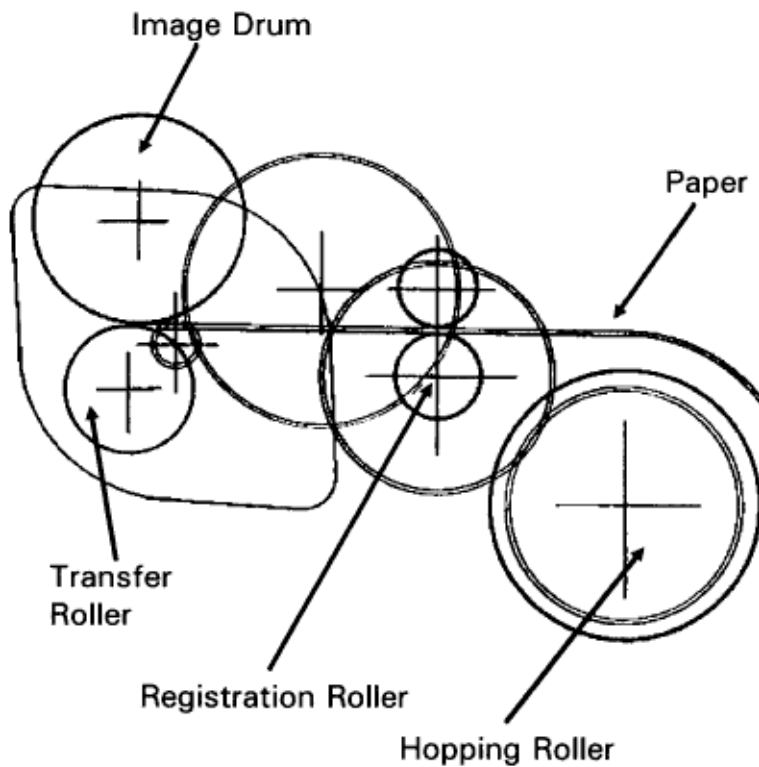

## 2.4.04 Charging

---

### 2.4.04 Charging

Charging applies -1.3 Kvdc to the charge roller. The charge roller contacts the image drum surface.

The charge roller has two layers: a conductive layer and a surface protective layer. The surface layer is flexible, which assures proper contact with the photosensitive drum.

The drum surface charges to approximately -750 vdc.

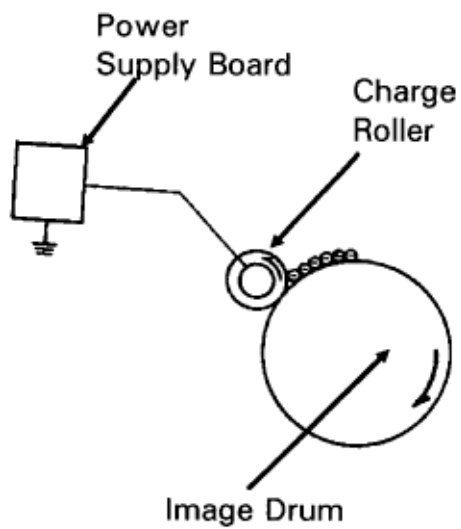

## 2.4.05 Exposing

### 2.4.05 Exposing

The image drum has four layers.

- Carrier Transfer Layer (CTL)
- Carrier Generation Layer (CGL)
- Underlayer (UL)
- Aluminum Base

The CTL and CGL make up the organic photo conductor layer (OPC), which is about 20 micrometers (mm) thick.

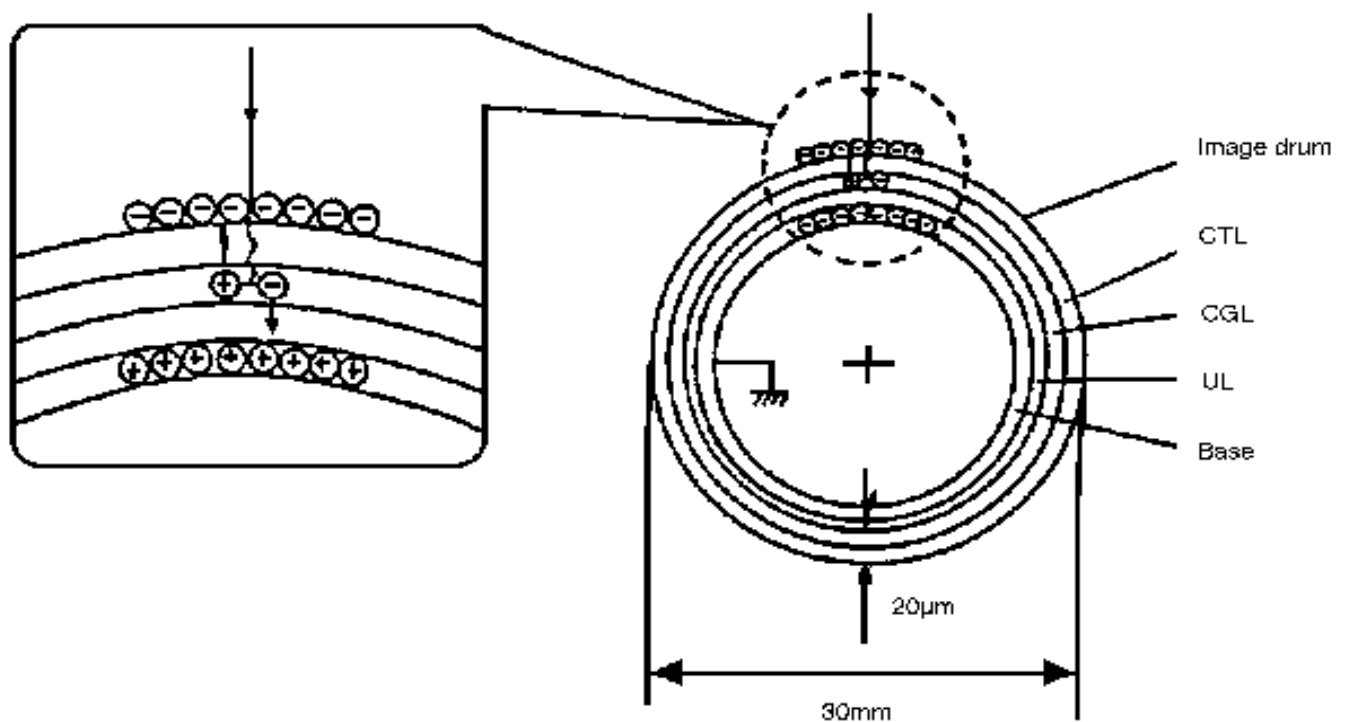

When light from the LED head irradiates the image drum surface, the light energy generates positive and negative carriers in the CGL. The positive carriers are moved to the CTL by an electrical field acting on the image drum. The negative carriers flow into the aluminum layer (ground).

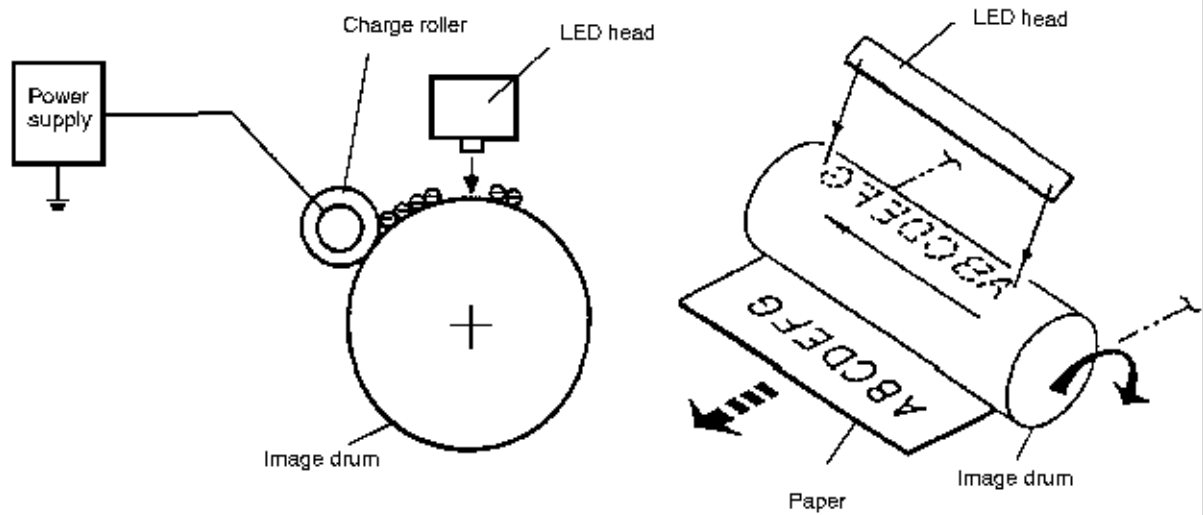

The positive carriers moved to the CTL combine with the negative charges on the image surface (accumulated by the contact charge of the charge roller), lowering the potential on the image drum surface. The resultant drop in the potential of the irradiated part of the image drum surface forms an electrostatic latent image on it. The surface potential on this irradiated part of the image drum is approximately -100 vdc.

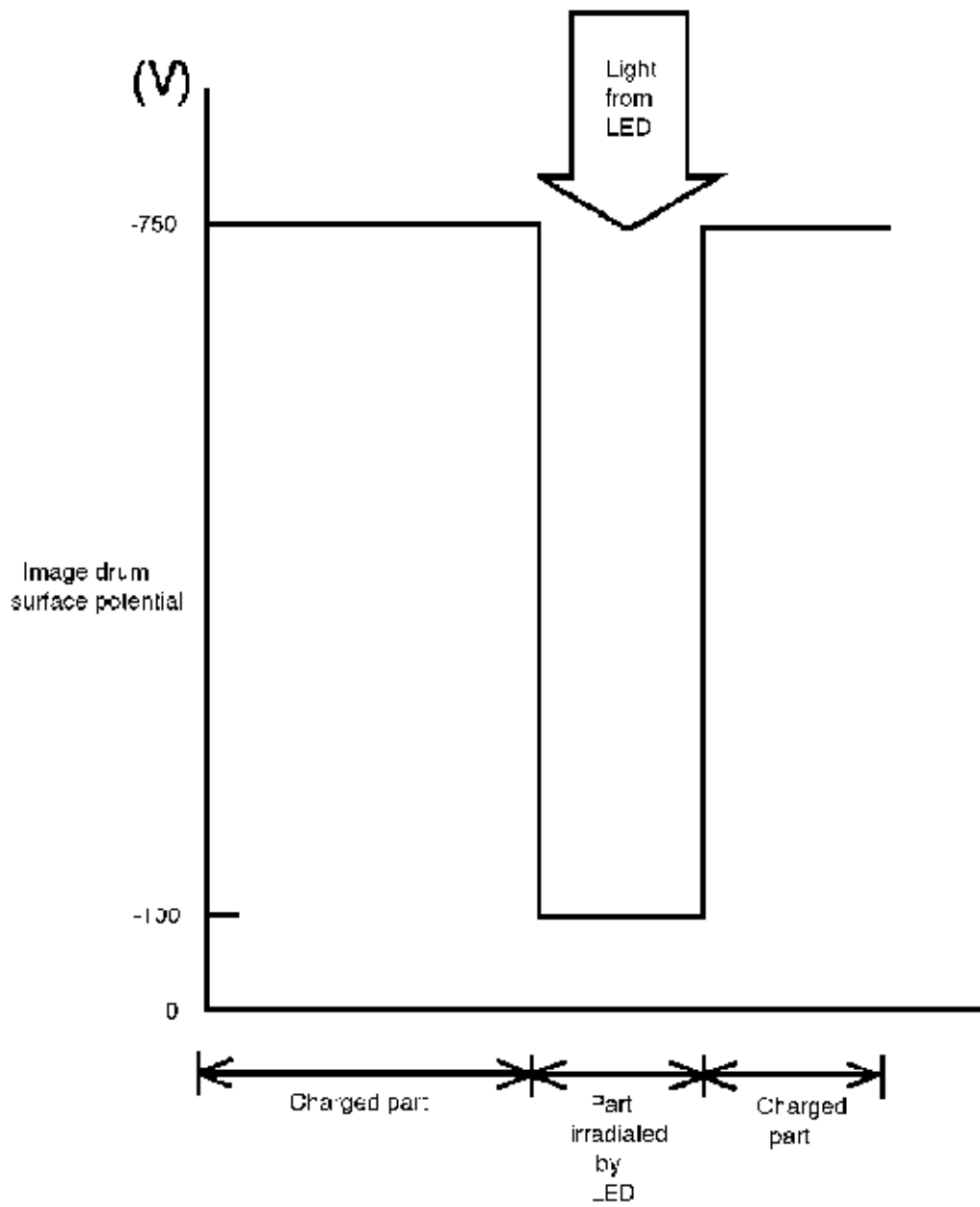

## 2.4.06 Developing

### 2.4.06 Developing

The electrostatic latent image formed on the image drum surface is developed into a visible image. Developing takes place when contact is made between the image drum and the developing roller.

As the toner supply roller rotates, toner is absorbed into the sponge type roller material.

A charged particle will be attracted to a particle having a MORE POSITIVE charge than its own.

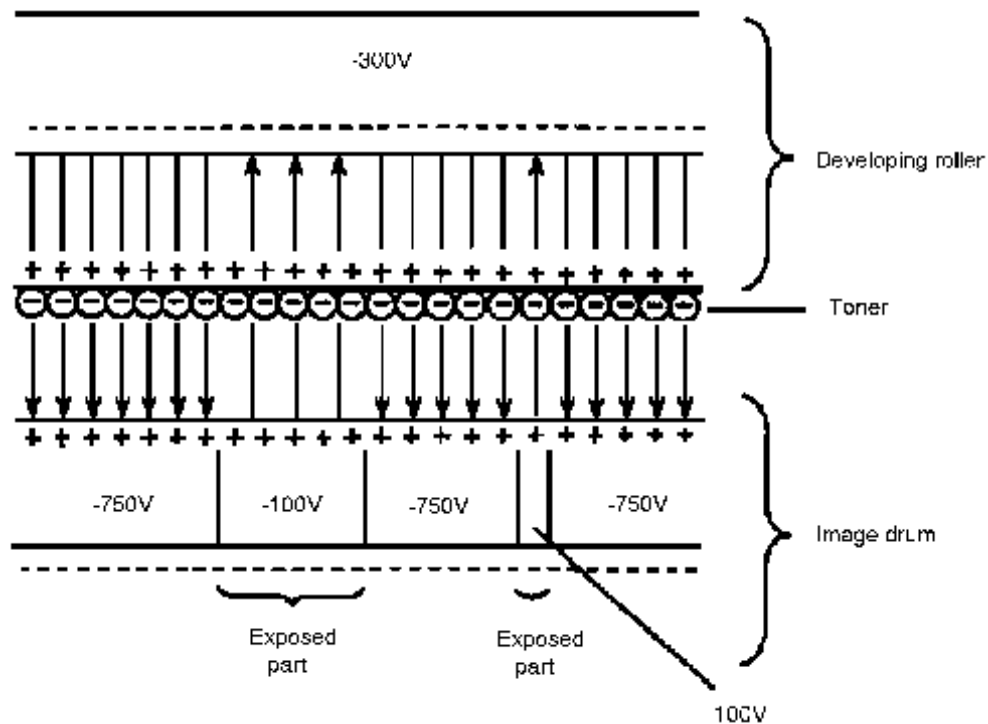

The developing roller surface is charged to -300 vdc and the toner supply roller is charged to -450 vdc. Since the development roller is charged more positive than the toner supply roller, the toner on the toner supply roller is attracted to the developing roller. The toner on the developing roller contacts the doctor blade, forming a thin coat of toner on the developing roller surface.

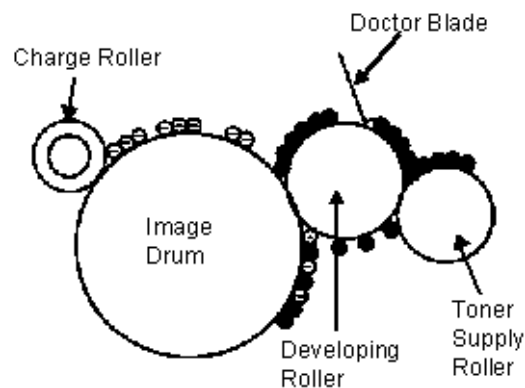

The exposed portion of the image drum contains a more positive charge than the development roller (-100 vdc vs. -300 vdc). Therefore, toner is attracted to the exposed areas of the image

drum, making the electrostatic latent image visible.

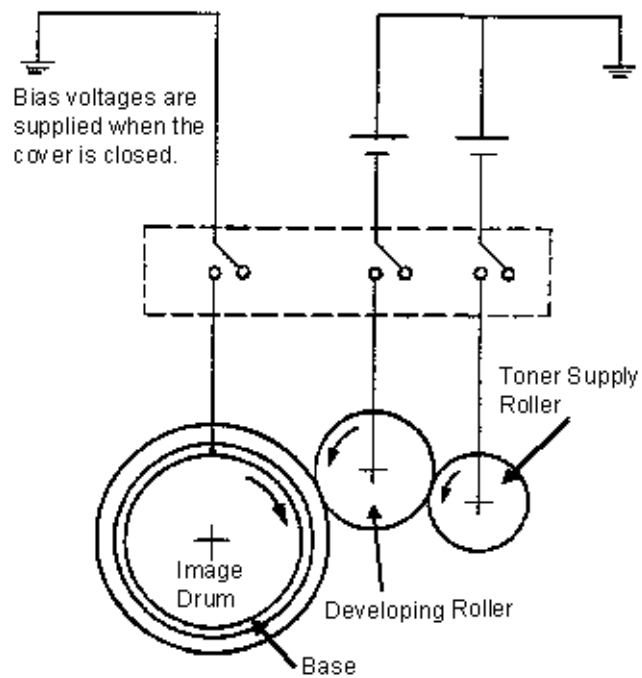

NOTE: The toner supply roller and the developing roller are supplied with the bias voltages required during the developing process. The toner supply roller is charged to -450 vdc. The developing roller is charged to -300vdc.



## 2.4.07 Transfer

---

### 2.4.07 Transfer

The transfer roller is made of a conductive sponge material. The roller keeps the paper in constant contact with the image drum. Paper is placed over the image drum surface. A positive charge (opposite in polarity to the toner) is applied to the paper from the reverse side.

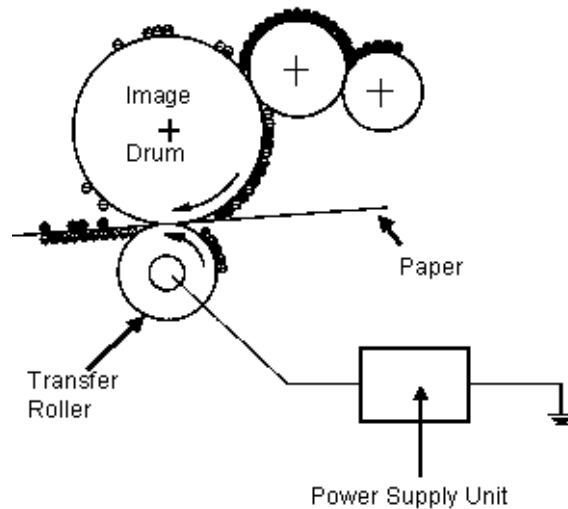

A charged particle will be attracted to a particle having a MORE POSITIVE charge than its own.

A high positive charge is applied to the transfer roller by the power supply board. This induced charge (on the surface of the transfer roller) is transferred to the paper when contact is made between the transfer roller and the paper. The lower side of the paper is positively charged. The negatively charged toner (on the image drum) is transferred to the upper side of the paper because of the positive charge on the lower side of the paper.

---

## 2.4.08 Fusing

---

### 2.4.08 Fusing

After transfer, the toner image is fused to the paper by heat and pressure. The paper passes between the fusing roller and the pressure roller. The fusing roller has a teflon coating and contains a 400 watt halogen lamp. A thermistor (which contacts the fusing roller) maintains the fusing roller temperature at approximately 150 degrees Celsius. A thermostat cuts off the voltage supply to the lamp if there is an abnormal temperature rise.

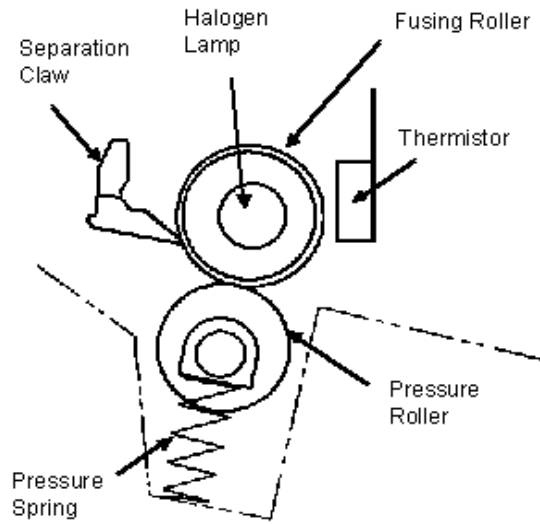

The pressure roller provides 2.5 Kg of pressure. This is generated by the pressure springs at each side of the roller.

---

## 2.4.09 Cleaning

---

### 2.4.09 Cleaning

The image drum is cleaned at the end of transfer. The residual toner on the image drum is attracted to the cleaning roller, which has a + 500 vdc static charge. This residual toner is accumulated in the image drum cartridge until the drum is replaced.

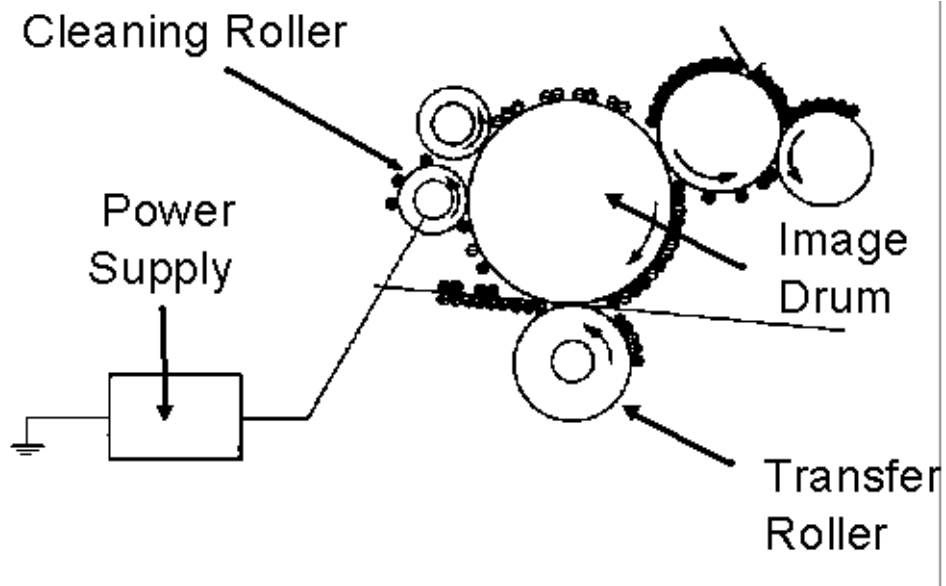

## 2.4.10 Printing

---

### 2.4.10 Printing

Refer to the Printing Process Diagram.

Printing is accomplished as follows.

Approximately - 1.3 Kvdc is supplied to the charge roller. This causes the drum to charge to approximately - 750 vdc.

The LED head is turned ON by the printer control board in accordance with signals from the main control board. This causes a latent electrostatic image to be formed on the surface of the drum.

Through the development process, a toner image replaces the electrostatic image.

A + 1 Kvdc charge is applied to the transfer roller. This causes the toner image to be transferred to the receive paper.

Heat and pressure cause the toner image to become fused to the receive paper. The 150 degree Centigrade fusing temperature is attained by turning a 400 watt halogen lamp ON. The fusing temperature is controlled by a thermistor. In the event of a thermistor failure, a temperature fuse will OPEN, turning off the quartz lamp, and preventing equipment damage.

The residual toner is removed from the drum.

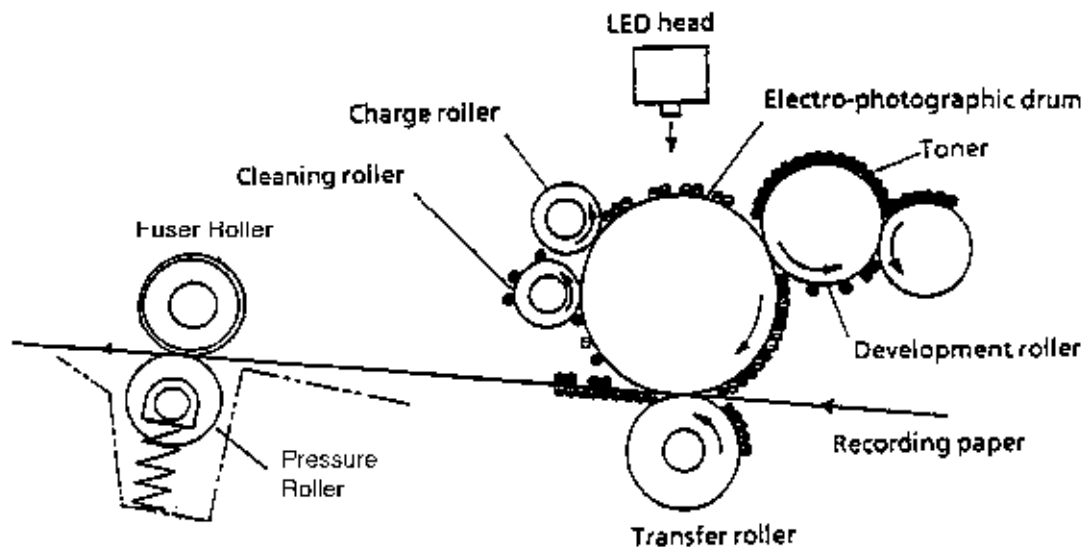

## **2.5 Sensors And Switches**

---

### **2.5 SENSORS AND SWITCHES**

---

# Sensor Location Diagram

## Sensor Location Diagram

### Top View

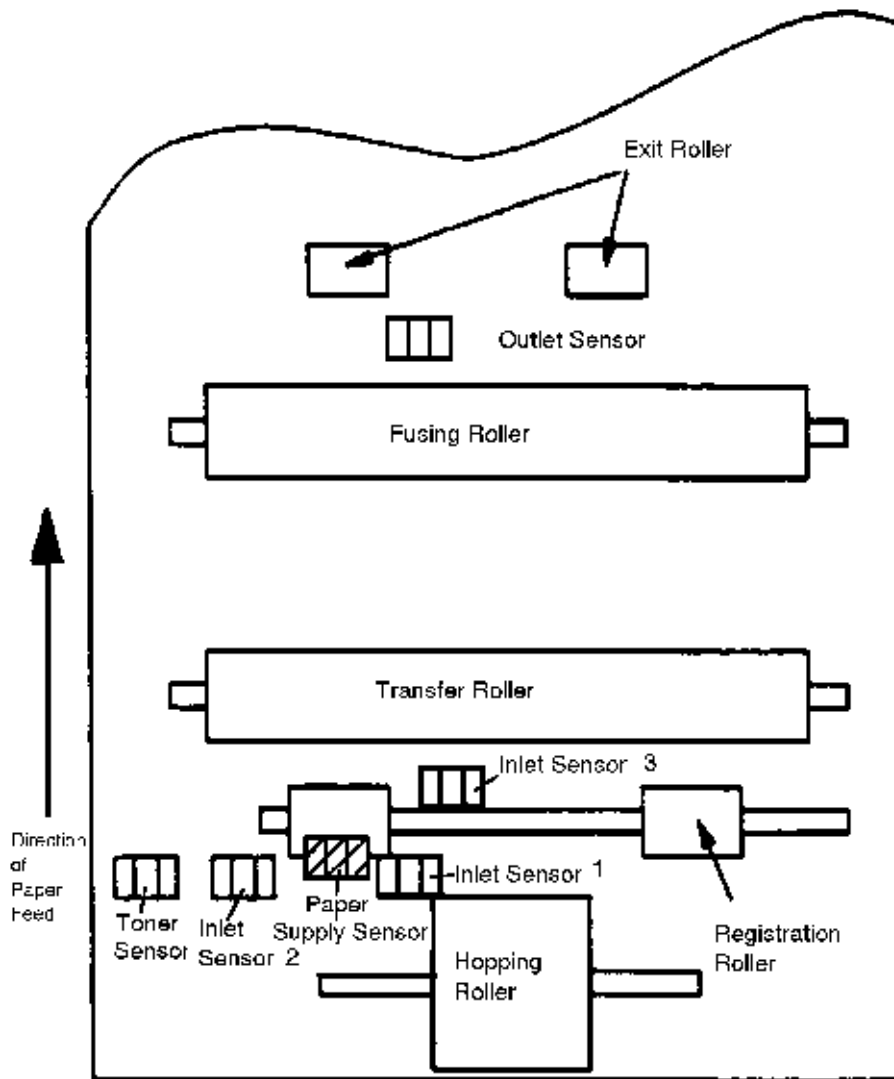

### Side View

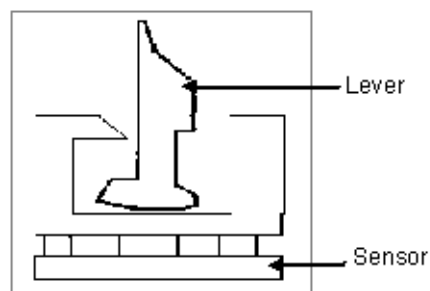

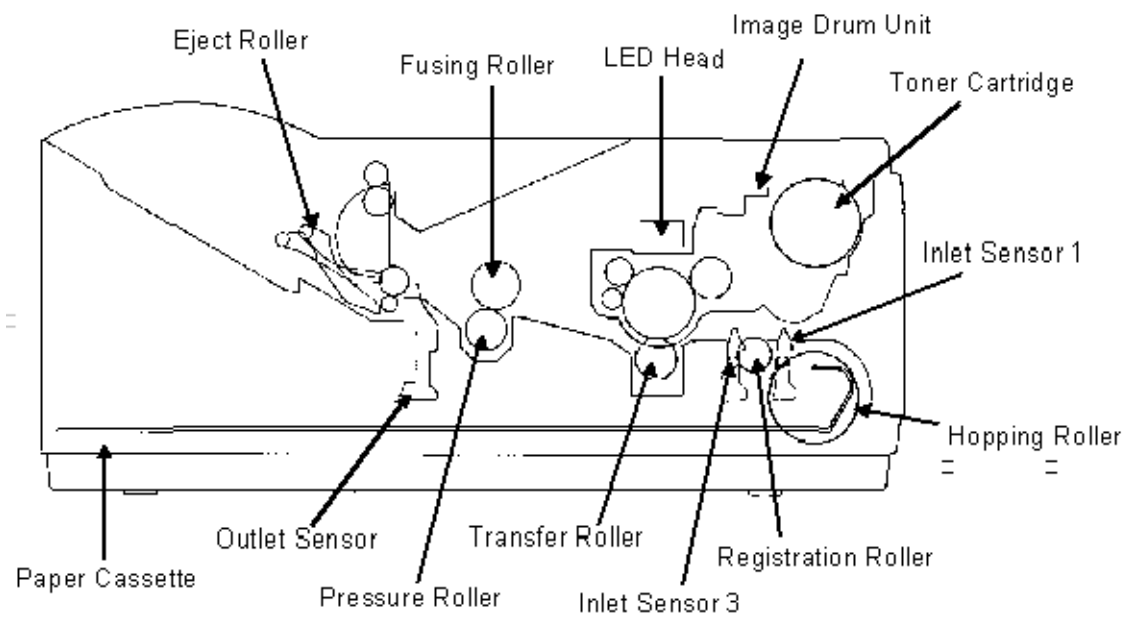

## 2.5.01 Paper Jam Detection

---

### 2.5.01 Paper Jam Detection

Paper jam detection monitors the location of paper when the printer is powered ON and during printing. If any of the following jams are present, the printing process is interrupted and the message PAPER JAM will be displayed on the LCD.

To return to the printing process, the paper jam condition MUST be cleared. This is accomplished by opening the upper cover, clearing the jam, and closing the cover.

#### **Paper Outlet Jam**

This jam occurs if the paper does NOT pass over the outlet sensor within a pre-determined period of time. However, the paper has already passed over the paper sensor.

#### **Paper Size Error**

The time interval between when the paper contacts the paper sensor and the outlet sensor determines which size (length) paper is being used.

This error occurs if the paper size of the loaded paper differs by + 45 mm or more from the paper size set by the menu.

#### **Cover Open Switch**

When the stacker cover is opened, the cover open microswitch on the power supply unit is deactivated. This disables the + 38 vdc and the high voltage power supply circuit. As a result, all high voltage outputs are interrupted. At the same time, the CVOPN signal is sent to the main control board to notify it of the OFF state of the microswitch. The main control board executes the cover open routine. The operation panel displays the message COVER OPEN.

---



# Paper Inlet Jam

## Paper Inlet Jam

This jam occurs when either of the following situations occur.

When the printer is powered ON, paper is at inlet sensor 1.

After the hopping operation is attempted three times, the leading edge of the paper does NOT reach inlet sensor 1.

## Paper Inlet Jam Timing Diagram

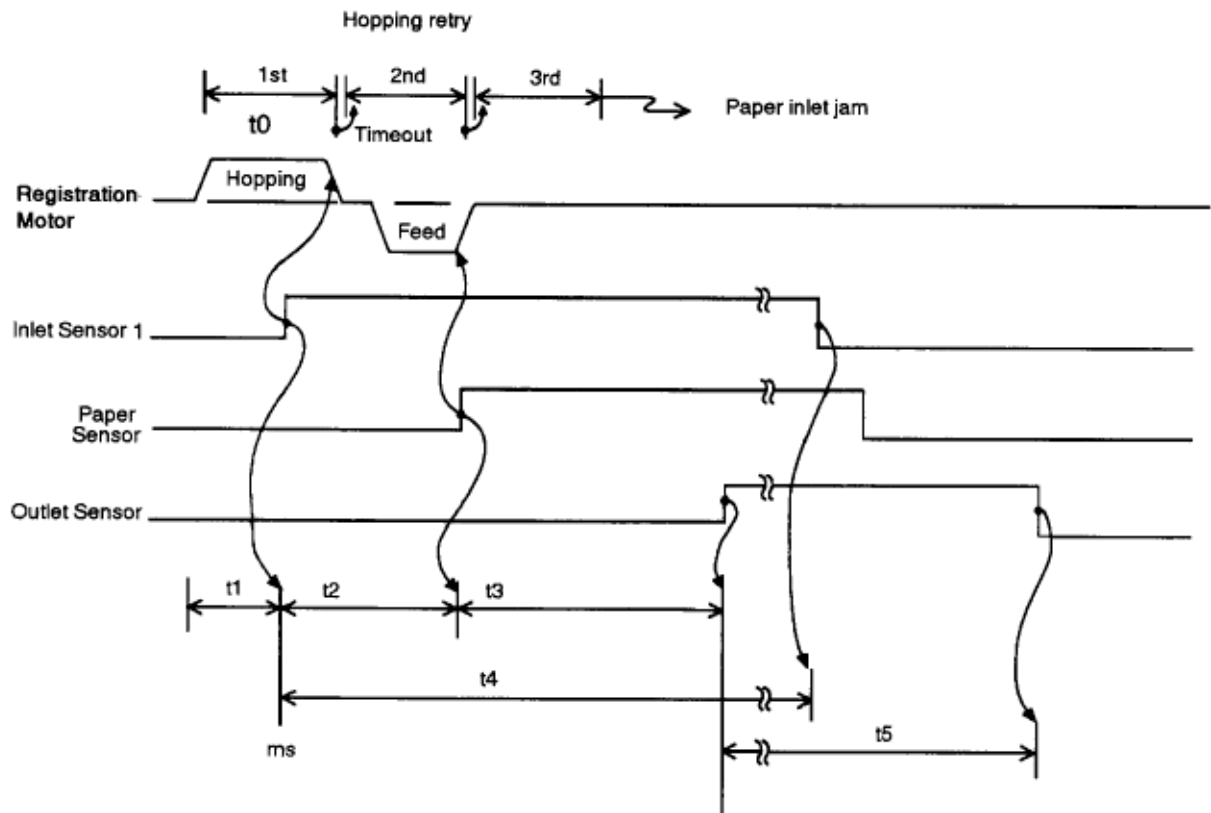

# Paper Feed Jam

## Paper Feed Jam

This jam occurs when either of the following conditions occur.

The paper does not pass over the paper sensor within a pre-determined period of time.

The leading part of the paper does not reach the outlet sensor within a pre-determined period of time after the paper has passed over the paper sensor.

## Paper Feed Jam Timing Diagram

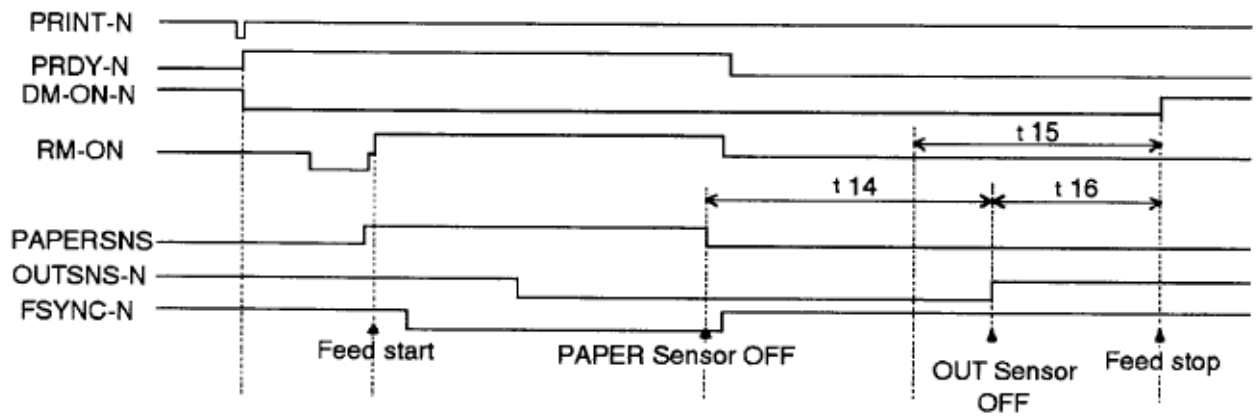

## 2.5.02 Toner Low Sensor

---

### 2.5.02 Toner Low Sensor

The toner well of the image drum cartridge contains a toner agitator. Whenever the image drum rotates, the toner agitator attempts to turn. A spring clip in the bottom of the toner well (along with the proper amount of toner) holds the agitator at the bottom of the well. However, when toner is distributed unevenly or an insufficient amount of toner is in the well, the toner agitator will rotate. Therefore, as long as the toner well contains an adequate supply of evenly distributed toner, the toner agitator will not rotate.

The toner sensor plate has a magnet embedded in it. Whenever the toner agitator is positioned at the bottom of the toner well, the toner sensor plate is magnetically attracted to the toner agitator. This causes the toner sensor plate to be lifted from the path of the toner sensor.

During a low toner condition, the toner agitator will rotate continuously. This causes the toner sensor to turn ON / OFF as the image drum rotates. The operator panel will then display the TONER LOW message.

During an unevenly distributed toner condition, the toner agitator will rotate until the toner is distributed sufficiently. This causes the toner sensor to turn ON / OFF for only a few image drum rotations. The operator panel will not display an error message since this is normal printer operation.

If the toner sensor remains activated (ON), the operator panel will display the TONER SNS message.

Customers may experience a "TONER SNS" or "TONER LOW" message with a brand new printer. This may occur even though a new toner cartridge and drum have been installed.

This can occur for the first 30 pages. Between 30 and 200 pages, the CPU will turn OFF the toner sensor. This will eliminate the message on the LCD. After 200 pages, the printer will begin checking for proper operation of the toner sensor flag.

Customers should use the printers for at least 30 pages. The "TONER SNS" or "TONER LOW" messages do not cause any print quality problems. The unit is in NO danger of suffering any damage. If the problem persists for more than thirty pages, customers are directed to contact a service center for warranty repair. This information is documented in TSB 5604()

---

## 2.5.03 Paper Path

---

### 2.5.03 Paper Path

#### **General Information**

The automatic and manual feed paths are different. In addition, the path will change if the paper is ejected face up or face down. Paper fed from the paper tray (automatic feed) and ejected face down will follow an "S" path. The path with the least amount of turns is a manual feed, face up ejection.

#### **Automatic Feed**

Load paper into the tray. The side to be printed on should be facing DOWN.

The leading edge of the paper should face the FRONT of the printer. Refer to either the face down or the face up section for further paper path details.

#### **Manual Feed**

Manually load the paper into the unit. The side to be printed on should be facing UP.

The leading edge of the paper should face the BACK of the printer. Refer to either the face down or the face up section for further paper path details.

#### **Face Down**

The hopping roller picks up the paper. The hopping roller transports the paper to the registration roller. The registration roller transports the paper to the image drum. Then, the paper passes between the fusing roller (on top) and the pressure roller (on the bottom). The paper is then routed upward and is ejected from inside the unit.

#### **Face Up**

The hopping roller picks up the paper. The hopping roller transports the paper to the registration roller. The registration roller transports the paper to the image drum. Then, the paper passes between the fusing roller (on top) and the pressure roller (on the bottom). The paper is then ejected from the inside of the unit.

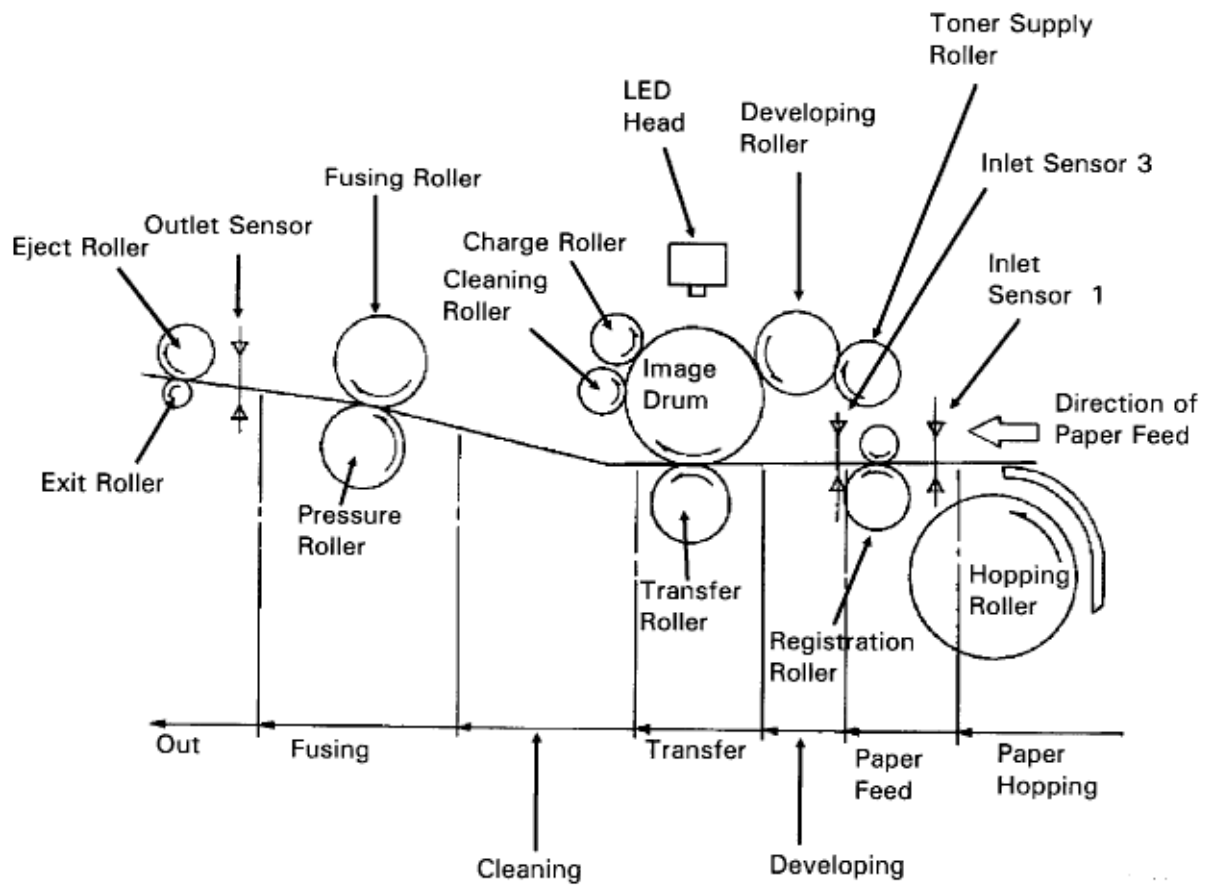

## Chapter 3

### 3.1.01 Maintenance General Information

---

#### 3.1.01 General Information

This section lists the parts replacement, adjustment, cleaning, lubrication, and shipping procedures.

Disassembly should not be performed unless absolutely necessary. NEVER perform disassembly on a malfunctioning unit until you have followed the failure analysis procedures in Section Four of this Service Handbook.

Follow the procedures listed in Adjustments and Service Settings. Adjustments may be required when either consumables or parts are replaced. Failure to perform these procedures could result in unnecessary service calls.

Cleaning procedures must be performed correctly if high print quality is to be achieved.

---

## 3.3 Adjustments And Service Settings

---

### 3.3 ADJUSTMENTS AND SERVICE SETTINGS

#### General Information

This section contains the procedures for checking and resetting counters and performing adjustments and service settings. These procedures may be required when replacing either consumables or parts. The disassembly / assembly procedures list the required adjustments and refer you to this section. Failure to perform these procedures may result in unnecessary service calls.

The adjustments and service settings are accomplished through the operator panel. Three different maintenance modes are used: user, system, and engine. Service setting changes are saved in the EEPROM located on the main controller board.

NOTE: End users should NOT access the system or engine maintenance modes.

---

## 3.3.01 User's Maintenance Mode

---

### 3.3.01 User's Maintenance Mode

#### General Information

This maintenance mode allows the user to access the following functions.

- Menu Reset..... (📄)
- Hex Dump..... (📄)
- Drum Counter Reset..... (📄)
- Op Menu..... (📄)
- X-Adjust (OL410e / OL410e-PS)..... (📄)
- Y-Adjust (OL410e / OL410e-PS)..... (📄)

#### User's Maintenance Mode Procedure

To enter user maintenance mode, perform the following procedure.

- Close the stacker cover.
- Install the paper cassette tray.
- Clear all error messages displayed on the operator panel.
- Power OFF the unit.
- Press and hold MENU 1 / Menu 2 while powering ON the unit.  
Continue to hold through both panel message displays.  
The operator panel displays the following for approximately two seconds.  
88888888  
88888888

- Release MENU 1 / Menu 2 once the operator panel displays  
USER MNT

- Press MENU 1 / Menu 2.  
The operator panel displays the following message.  
MENU  
RESET

- 7) Press MENU 1 / Menu 2.  
The operator panel displays the following message.  
HEX DUMP

- 8) Press MENU 1 / Menu 2.  
The operator panel displays the following message.  
DRUM CNT  
RESET

- 9) Press MENU 1 / Menu 2.  
The operator panel displays the following message.  
OP MENU  
ENABLE

#### **For OL410 / OL410e-PS models only**

- 10) Press MENU 1 / Menu 2.  
The operator panel displays the following message.  
X ADJUST  
0 mm \*

- 11) Press MENU 1 / Menu 2.



The operator panel displays the following message.

Y ADJUST

0 mm \*

NOTE:

- To work with any of the user maintenance mode items, press ENTER / Copies.
  - Press LAST - / Paper Size or NEXT + / Demo to move through the settings for the user maintenance mode items.
-

# Menu Reset / Menu Print

---

## Menu Reset / Menu Print

**CAUTION:**

Menu Reset returns ALL menu level 1 settings to factory defaults.  
ALL customized menu level 1 settings will be lost.  
ALWAYS print the menu before doing a menu reset.

Double Click to see	Menu Settings Level 1.....	( )
	Menu Settings Level 2.....	( )
	Sample Page OL400e.....	( )
	Sample Page OL410e.....	( )
	Sample Page OL410e-PS.....	( )

### Procedure - Menu Print

To print the menu, follow this procedure.

- 1) Press ON-LINE to take the printer OFF-LINE.
- 2) Press PRINT MENU / Print Fonts to print the menu.

### Procedure - Menu Reset

To reset the menu, perform the following procedure.

**CAUTION:**

Menu Reset returns ALL menu level 1 settings to factory defaults.  
ALL customized menu level 1 settings will be lost. ALWAYS print the menu before doing a menu reset.

- 1) Close the stacker cover.
- 2) Install the paper cassette tray.
- 3) Clear all error messages displayed on the operator panel.
- 4) Power OFF the unit.
- 5) Press and hold MENU 1 / Menu 2 while powering ON the unit.  
The operator panel displays the following for approximately two seconds.  
88888888  
88888888  
The operator panel displays the following message.  
USER MNT
- 6) Press MENU 1 / Menu 2.  
The operator panel displays the following message.  
MENU  
RESET
- 7) Press ENTER / Copies.  
The operator panel displays the following message for approximately 15 seconds.  
WARM UP
- 8) The unit will then go ON-LINE.  
The operator panel displays the following message.

ON-LINE HPIIP (OL400e)	ON-LINE HPIII (OL410e)	ON-LINE ADOBE PS (OL410e/PS)
------------------------------	------------------------------	------------------------------------

## Menu Settings - Level 1

### Menu Settings - Level 1

Factory defaults are printed in **bold**.

Category	Items	Options	Explanation
PRINTER LANGUAGE (OL400e only)	EMULATE	HPIIP	
PRINTER LANGUAGE (OL410e only)	EMULATE	HPIII (OL410e)	
PRINTER LANGUAGE (OL410e-PS only)	EMULATE	Adobe PS (OL410e-PS)	
TRAY SELECT	PAPER IN	<b>TRAY 1</b>	Select paper tray.
		TRAY 2 <i>Appears if installed</i>	Select second paper tray
		MANUAL	Select manual paper feed.
		FEEDER <i>Appears if installed</i>	Select feeder.
	AUTOTRAY <i>Appears if tray 2 installed</i>	<b>ON, OFF</b>	Set On, printer will switch to second tray when first tray is empty.
PAPER SIZE	TRAY 1	<b>LETTER</b> EXEC LEGAL 14 LEGAL 13 A4 SIZE A5 SIZE A6 SIZE B5 SIZE FREE	Select paper size in tray 1. 8.5" X 11" 7.25" X 10.5" 8.5" X 14" <i>(with optional legal tray)</i> 8.5" X 13" <i>(with optional legal tray)</i> 210 mm 297 mm 148 mm 210 mm 105 mm X 148 mm 176 mm X 250 mm Allows printing on custom size paper

	TRAY 2 <i>Appears if installed</i>	<b>LETTER</b> , EXEC, LEGAL 14, LEGAL 13, A4 SIZE, A5 SIZE, A6 SIZE, B5 SIZE, FREE	Select paper size in tray 2 if installed.
	MANUAL	<b>LETTER</b> , EXEC, LEGAL 14, LEGAL 13, A4 SIZE, A5 SIZE, A6 SIZE, B5 SIZE, FREE  COM-10 MONARCH DL ENV	Select paper size for manual feed.  4.12" X 9.50" Envelope 3.87" X 7.50" Envelope 110 mm X 220 mm Envelope
	FEEDER <i>Appears if installed</i>	<b>COM-10</b> , MONARCH, DL ENV, C5 ENV, LETTER, EXEC, LEGAL 14, LEGAL 13, A4 SIZE, A5 SIZE, A6 SIZE, B5 SIZE, FREE	Select envelope/paper size in feeder if installed
MEDIA TYPE	TRAY 1 MANUAL	<b>MEDIUM</b> , LIGHT	Normal setting for 20-28lb paper. Select LIGHT if 16-20lb paper wrinkles or curls
COPIES		1 to 99	Select number of copies to print for each document
FONTS & SYMBOLS	FONT SRC	<b>RESIDENT</b> , CARD <i>Appears if installed, DLLSOFT Appears if loaded</i>	Select font source.
	FONT NO	<b>I000</b> to I013, <b>I000</b> to I020 (OL410e)	Select font by ID number (see font print sample). Prefix indicates font source: I=internal (resident); C=card; S=soft font.

	FONT CPI ( <i>OL410e</i> ) Appears if selected font is scalable/fixed spaced	<b>10.00</b> , 0.44 to 99.99	Select number of characters printed in a horizontal inch (pitch) when scalable font with fixed spacing is selected. (0.01 mm increments). Character height (point size) adjusts accordingly.
	FONT HGT ( <i>OL410e</i> ) Appears if selected font is scalable/proportional spaced	<b>12.00</b> , 4.00 to 999.75	Select point size (height) of characters when scalable font with proportional spacing is selected. (0.25 mm increments). Horizontal spacing adjusts accordingly.
	SYMBOL	ROMAN-8	Roman-8 is the standard HP set.
	HP CART ( <i>OL410E &amp; 410e-PS</i> )	<b>NONE</b> , F,B	HP font cartridge designations. Select F or B to agree with software or select NONE.
PAGE LAYOUT	ORIENT	<b>PORTRT</b> , LANDSCP	
	LINES/PG	<b>60 LNS</b> , 5 to 128 LNS	Select number of lines on page.
	A4 WIDTH	<b>78 COL</b> , 80 COL	Use this option for A4 size paper to select 78 columns or condense 80 columns so characters will fit on a line.
	BLNKSKIP	<b>OFF</b> , ON	Set ON printer will ignore FF code when buffer is empty. (Sometimes Word for Windows will print an extra blank page.)

HOST I/F		AUTO I/F, PARALLEL, RS232C  Adobe-PS Local Talk or RS-422	Select active interface.
----------	--	--	-----------------------------

---

## Menu Settings - Level 2

### Menu Settings - Level 2

Factory defaults are printed in **bold**.

Category	Items	Options	Explanation
PRINT MODE (OL410e and OL410e-PS)			Select printing mode.
		<b>OKI600</b> , OKI300	OKI600 requires OL410e driver. HPIII Emulation supports OKI300
	SMOOTHNG Appears if PRINT MODE is OKI600	MEDIUM, DARK	Smoothing widens/blackens characters and graphic dots so edges appear more crisp and less jagged
MEMORY USAGE (OL400e and OL410e-PS Only)	PAGEPROT Appears if optional RAM is installed	<b>Off</b> , Letter, Legal, A4	Reserves area in memory for page size selected; eliminates print overruns
	PAGE BUF (OL410e), OKI600	<b>AUTO</b> , 360KB to 3.96MB, FUL LTR Requires 5MB RAM, FUL A4 Requires 5MB RAM	Reserve work area in memory for building image insuring that entire page prints; eliminates print overruns. AUTO allows printer to maximize RAM areas for best results. Other areas may be customized if file size of graphic image is known
	300DPI	<b>AUTO</b> , 180KB to 900KB, FUL LTR, FUL A4, FUL LGL	

	REC BUFF	AUTO (OL410e), 8KB, 20KB, 50KB, 100KB, 1MB	Select amount of memory devoted to holding received data; larger setting improves computer return to application time. OL400e requires optional RAM for 1 MB setting
	FONT PROT OKI600	<b>AUTO</b> , OFF, 100 KB to 3.1MB	Reserves a section of memory for downloading fonts; improves printing speed by saving previously created fonts. Will take memory away from total print buffer and REC BUFF
	300DPI	AUTO, OFF, 100KB to 3.6MB	
AUTO OPERATION	AUTOCONT	<b>OFF</b> , ON	If ON, software or data error will cause printer to display error message then continue to print; Set Off, printer will stop printing; press RECOVER to continue.
	AUTOEJCT	<b>OFF</b> , 15 SEC, 30 SEC, 1 MIN	When set to other than Off: if printer doesn't receive data within the set time (15 Sec, 30 Sec, or 1 Min), current page will print and eject. Meant for use with software that doesn't issue Form Feed command at end of last page. When Off, printer won't print last page without a Form Feed
DARKNESS CONTROL	DARKNESS	<b>0</b> , +1, +2, -2, -1	Control print density. Negative values lighten, positive values darken.



POWER SAVING	PWR SAVE	<b>ENABLE, DISABLE</b>	Enable: reduces power consumption. 8 minutes after printer stops receiving data fuser heating element shuts off; after 12 additional minutes fan shuts off. When printer receives more data, fuser warms up before printing begins. Disable: fuser and fan are always on, printer is ready to print at all times
TONER SAVING (OL400e)		<b>TNR SAVE DISABLE, MEDIUM, LIGHT</b>	Use this feature to conserve toner and reduce printing costs when you are printing rough drafts or proof copies. Medium reduces toner by 30%, light reduces toner by 50%
PARALLEL I/F	I-PRIME	<b>OFF, ON</b>	Set On, I-Prime signal resets printer. Set OFF, or HOST I/F is AUTO IF, printer ignores signal
RS232C SERIAL	FLOW CTL	<b>DTR HI, DTR LO, XONXOFF, RBSTXON</b>	Select serial protocol.
	BAUDRATE	<b>9600, 19200, 300, 600, 1200, 2400, 4800</b>	Select transmission rate in bits per second (bps)
	DATABITS	<b>8 BITS, 7 BITS</b>	Select serial interface data bit format.
	PARITY	<b>NONE, EVEN, ODD</b>	Select serial interface parity type.
	MIN BUSY	<b>200 mSEC, 1 SEC</b>	Set length of busy signal when Ready/Busy (DTR) protocol is selected.

LANGUAGE		ENGLISH, DEUTSCH, FRANCIS, ITLIANO, CASTLAN, SVENSKA, NORSK, DANSK, NEDERL, PORTUGUÊS	Select language displayed. German French Italian Spanish Swedish Norwegian Danish Dutch Portuguese
----------	--	--	--

---

# Sample Menu - OL400E

## Sample Menu - OL400e

<b>OL400e LED Page Printer</b>			
Program ROM : F/W 01.13 A00 FONT 01.00			
Page Memory : 0.5M Bytes Installed			
<hr/>			
<b>Operator Panel Menu Settings</b>			
<b>Level-1</b>			
<b>Category</b>	<b>Item</b>	<b>Factory</b>	<b>User</b>
<hr/>			
<b>Common</b>			
PRINTER LANGUAGE	EMULATE	HPIIP	HPIIP
TRAY SELECT	PAPER IN	TRAY	TRAY
PAPER SIZE	TRAY	LETTR	LETTR
	MANUAL	LETTR	LETTR
COPIES	COPIES	1	1
<hr/>			
<b>HP® LaserJet® IIP Emulation</b>			
FONTS & SYMBOLS	FONT SRC	RESIDENT	RESIDENT
	FONT No.	I000	I000
	SYMBOL	Roman-8	Roman-8
	HP CART	NONE	NONE
PAGE LAYOUT	ORIENT	PORTRT	PORTRT
	LINES/PG	60 LNS	60 LNS
	A4 WIDTH	78 COL	78 COL
	BLNKSKIP	OFF	OFF
<hr/>			
<b>Common</b>			
HOST I/F	HOST I/F	AUTO IF	AUTO IF
<hr/>			
<b>Level-2</b>			
MEMORY USAGE	REC BUFF	8 KB	8 KB
AUTO OPERATION	AUTOCONT	OFF	ON
	AUTOEJECT	OFF	15 SEC
DARKNESS CONTROL	DARKNESS	0	+2
POWER SAVING	PWR SAVE	ENABLE	DISABLE
PARALLEL I/F	I-PRIME	OFF	ON
RS232C SERIAL	FLOW CTL	DTR HI	DTR HI
	BAUDRATE	9600	9600
	DATABITS	8 BITS	8 BITS
	PARITY	NONE	NONE
	MIN BUSY	200mSEC	200mSEC
<hr/>			
HP and LaserJet are registered trademarks of Hewlett-Packard Company.			

# Sample Menu - OL410E

## Sample Menu - OL410e

### OL410e LED PAGE PRINTER

Program ROM : F/W 01.40 A00 FONT 01.60  
 Page Memory : 1M Bytes Installed

#### Operator Panel Menu Settings

##### Level-1

Category	Item	Factory	User
<b>Common</b>			
PRINTER LANGUAGE	EMULATION	HPIII	HPIII
TRAY SELECT	PAPER FEED	TRAY1	TRAY1
PAPER SIZE	TRAY1 PAPER SIZE	LETTER	LETTER
	MANUAL FEED	LETTER	LETTER
COPIES	COPIES	1	1
<b>HP® LaserJet® III Emulation</b>			
FONTS & SYMBOLS	FONT SOURCE	RESIDENT	RESIDENT
	FONT No.	1000	1000
	FONT PITCH	10.00 CPI	10.00 CPI
	SYMBOL SET	Roman-8	Roman-8
PAGE LAYOUT	ORIENTATION	PORTRAIT	PORTRAIT
	LINES PER PAGE	60 LINES	60 LINES
	A4 PRINT WIDTH	78 COLUMN	78 COLUMN
	BLANK SKIP	OFF	OFF
<b>Common</b>			
HOST I/F	HOST INTERFACE	AUTO INTERFACE	AUTO INTERFACE

##### Level-2

PRINT MODE	MODE	OKI600dpi	OKI600dpi
	SMOOTHING	MEDIUM	MEDIUM
MEMORY USAGE	PAGE BUFFER	AUTO	AUTO (360KB)
	RECEIVE BUFFER	AUTO	AUTO (8KB)
	FONT PROTECTION	AUTO	AUTO (0KB)
AUTO OPERATION	AUTO CONTINUE	OFF	OFF
	AUTO EJECT	OFF	OFF
DARKNESS CONTROL	DARKNESS	0	0
POWER SAVING	POWER SAVE	ENABLE	ENABLE
PARALLEL I/F	I-PRIME	OFF	OFF
RS232C SERIAL	FLOW CONTROL	DTR HI POLARITY	DTR HI POLARITY
	BAUD RATE	9600 BAUD	9600 BAUD
	DATA BITS	8 BITS	8 BITS
	PARITY	NONE	NONE
	MIN. BUSY TIME	200 mSEC	200 mSEC
LANGUAGE	LANGUAGE	ENGLISH	ENGLISH

HP and LaserJet are registered trademarks of Hewlett-Packard Company.

## Sample Menu - OL410E/PS

---

Sample Menu - OL410e/PS

# OL410e/PS

## LED Page Printer

<b>Printer Language</b>	Adobe PS
<b>Paper Feed</b>	Tray 1
<b>Auto Tray Switch</b>	Off
<b>Paper Size</b>	
Tray 1	Letter
Tray 2	---
Feeder	---
<b>Media Type</b>	
Tray 1	Medium
Tray 2	---
Feeder	---
<b>RS422 Port</b>	LocalTalk

<b>PostScript Version</b>	2014.105
<b>Program ROM</b>	F/W 47
<b>RAM Size</b>	2097152
<b>Adobe Memory Booster</b>	

<b>Print Mode</b>	OKI600dpi
<b>Smoothing</b>	Dark
<b>Do Jam Recovery</b>	Off
<b>Do Start Page</b>	Off
<b>Allow Job Reset</b>	Off
<b>Manual Timeout</b>	1 Minute
<b>Wait Timeout</b>	40 Seconds
<b>Font Cache</b>	Auto
<b>Error Report</b>	Off
<b>Job Switch</b>	Per Job
<b>Darkness</b>	0
<b>Power Saving</b>	Disabled
<b>RS232C Serial</b>	
<b>Flow Control</b>	DTR HI Polarity
<b>Baud Rate</b>	9600
<b>Data Bits</b>	8
<b>Parity</b>	None
<b>RS422 Serial</b>	
<b>Baud Rate</b>	9600
<b>Data Bits</b>	8
<b>Parity</b>	None
<b>Language</b>	English



Adobe PostScript

Adobe, PostScript, Adobe Memory Booster and the PostScript Logo are registered trademarks of Adobe Systems Incorporated, which may be registered in certain jurisdictions. AppleTalk is a trademark of Apple Computer Inc.

# Hex Dump

---

## Hex Dump

### General Information

Data received by the printer is converted to hexadecimal codes and printed when the printer is in HEX DUMP mode.

If the amount of data received is more than one page, printing will automatically activate.

If the amount of data received is less than one page, you may have to manually activate printing.

To print the page, you can do one of the following procedures.

- Press ON-LINE to place the printer OFF-LINE.
- Press FORM FEED / Tray Select.
- or
- Set AUTO EJECT to ON in the menu.

### Procedure

To enter hex dump mode, perform the following procedure.

- Close the stacker cover.
- Install the paper cassette tray.
- Clear all error messages displayed on the operator panel.
- Power OFF the unit.
- Press and hold MENU 1 / Menu 2 while powering ON the unit.  
The operator panel displays the following for approximately two seconds.  
88888888  
88888888
- Release MENU 1 / Menu 2 once the operator panel displays the following message.  
USER MNT
- Press MENU 1 / Menu 2.  
The operator panel displays the following message.  
MENU  
RESET
- Press MENU 1 / Menu 2.  
The operator panel displays the following message.  
HEX DUMP
- Press ENTER / Copies  
The operator panel displays the following message for approximately 15 seconds.  
WARM UP
- The unit will go ON-LINE.  
The operator panel displays the following message.  
ON-LINE  
HEX DUMP

To exit Hex Dump, power OFF the unit.

### Hexadecimal Codes (US ASCII)

Hex	Decimal	Symbol	Hex	Decimal	Symbol	Hex	Decimal	Symbol
00	0	NUL	2C	44	,	58	88	X
01	1	SOH	2D	45	-	59	89	Y
02	2	STX	2E	46	.	5A	90	Z
03	3	ETX	2F	47	/	5B	91	[
04	4	EOT	30	48	0	5C	92	\
05	5	ENQ	31	49	1	5D	93	]
06	6	ACK	32	50	2	5E	94	^
07	7	BEL	33	51	3	5F	95	_
08	8	BS	34	52	4	60	96	`
09	9	HT	35	53	5	61	97	a
0A	10	LF	36	54	6	62	98	b
0B	11	VT	37	55	7	63	99	c
0C	12	FF	38	56	8	64	100	d
0D	13	CR	39	57	9	65	101	e
0E	14	SO	3A	58	:	66	102	f
0F	15	SI	3B	59	;	67	103	g
10	16	DLE	3C	60	<	68	104	h
11	17	DC1	3D	61	=	69	105	i
12	18	DC2	3E	62	>	6A	106	j
13	19	DC3	3F	63	?	6B	107	k
14	20	DC4	40	64	@	6C	108	l
15	21	NAK	41	65	A	6D	109	m
16	22	SYN	42	66	B	6E	110	n
17	23	ETB	43	67	C	6F	111	o
18	24	CAN	44	68	D	70	112	p
19	25	EM	45	69	E	71	113	q
1A	26	SUB	46	70	F	72	114	r
1B	27	ESC	47	71	G	73	115	s
1C	28	FS	48	72	H	74	116	t
1D	29	GS	49	73	I	75	117	u
1E	30	RS	4A	74	J	76	118	v
1F	31	US	4B	75	K	77	119	w
20	32	SP	4C	76	L	78	120	x
21	33	!	4D	77	M	79	121	y
22	34	*	4E	78	N	7A	122	z
23	35	#	4F	79	O	7B	123	{
24	36	\$	50	80	P	7C	124	
25	37	%	51	81	Q	7D	125	}
26	38	&	52	82	R	7E	126	~
27	39	'	53	83	S	7F	127	
28	40	(	54	84	T			
29	41	)	55	85	U			
2A	42	*	56	86	V			
2B	43	+	57	87	W			



# Drum Counter Reset

---

## Drum Counter Reset

### General Information

The drum counter should be reset when the image drum is replaced.

This message will be displayed on the operator panel when the image drum should be replaced.

CHG DRUM

The counter **MUST** be reset to clear this message.

The drum count is **NOT** the same as the page count or the drum count total.

### Procedure

To view the drum count, perform the following procedure.

- Close the stacker cover.
- Install the paper cassette tray.
- Clear all error messages displayed on the operator panel.
- Power OFF the unit.
- Press and hold MENU 1 / Menu 2 while powering ON the unit.
  - The operator panel displays the following for approximately two seconds.  
88888888  
88888888
- Release MENU 1 / Menu 2 once the operator panel displays the following message.  
USER MNT
- Press MENU 1 / Menu 2.
- The operator panel displays the following message.  
MENU  
RESET
- Press MENU 1 / Menu 2.
  - The operator panel displays the following message.  
HEX DUMP
- Press MENU 1 / Menu 2.
  - The operator panel displays the following message.  
DRUM CNT  
RESET
- Press ENTER / Copies.
  - The operator panel displays the following message.  
DRUM CNT  
RESETTING
- The unit will go ON-LINE.
- The operator panel displays the following message.

ON-LINE  
HPIIP  
(OL400e)

ON-LINE  
HPIII  
(OL410e)

ON-LINE  
ADOBE PS  
(OL410e/PS)

---

# Operator Panel Menu Enable / Disable

---

## Operator Panel Menu Enable / Disable

### General Information

This function enables or disables the operator panel menu functions.

When this function is DISABLED, all control panel buttons except ON-LINE are disabled.

The default is for the operator panel to be enabled.

### Procedure

To enable or disable the operator menu, perform the following procedure.

- Close the stacker cover.
- Install the paper cassette tray.
- Clear all error messages displayed on the operator panel.
- Power OFF the unit.
- Press and hold MENU 1 / Menu 2 while powering ON the unit.
  - The operator panel displays the following for approximately two seconds.  
88888888  
88888888
- Release MENU 1 / Menu 2 once the operator panel displays the following message.  
USER MNT
- Press MENU 1 / Menu 2.
  - The operator panel displays the following message.  
MENU  
RESET
- Press MENU 1 / Menu 2.
  - The operator panel displays the following message.  
HEX DUMP
- Press MENU 1 / Menu 2.
  - The operator panel displays the following message.  
DRUM CNT  
RESET
- Press MENU 1 / Menu 2.
  - The operator panel displays the following message.  
OP MENU  
ENABLE
- Press ENTER / Copies
  - The operator panel displays the following message.  
OP MENU  
ENABLE
  - An asterisk will follow the word ENABLE if the op menu is enabled.
- Press LAST - / Paper Size or NEXT + / Demo to toggle between ENABLE and DISABLE.
  - The operator panel displays the following message.  
OP MENU      OP MENU  
ENABLE      or      DISABLE

An asterisk will follow the word ENABLE or DISABLE to show the selection.

- Press ENTER / Copies to select the setting.

An asterisk will follow the word ENABLE or DISABLE to show the selection.

- Press ON-LINE to save the setting and exit the user maintenance mode.

The operator panel displays the following message for approximately 15 seconds.

WARM UP

The operator panel displays the following message.

ON-LINE  
HPIIP  
(OL400e)

ON-LINE  
HPIII  
(OL410e)

ON-LINE  
ADOBE PS  
(OL410e/PS)

---

# X Adjust

---

## X Adjust

### General Information

This function sets the horizontal position of the first printable area (print start position).

Changes are written to the EEPROM.

The print start position is the distance from the leading edge of the paper where printing can begin. Print start positions can vary between printers.

**The default is 0.**

Negative values of the print start positions move the position closer to the leading edge of the paper.

Positive values of the print start positions move the position away from the leading edge of the paper.

### Procedure

To enable or disable the operator menu, perform the following procedure.

- Close the stacker cover.
- Install the paper cassette tray.
- Clear all error messages displayed on the operator panel.
- Power OFF the unit.
- Press and hold MENU 1 / Menu 2 while powering ON the unit.
  
- The operator panel displays the following for approximately two seconds.  
88888888  
88888888
  
- Release MENU 1 / Menu 2 once the operator panel displays the following message.  
USER MNT
  
- Press MENU 1 / Menu 2.  
The operator panel displays the following message.  
MENU  
RESET
  
- Press MENU 1 / Menu 2.  
The operator panel displays the following message.  
HEX DUMP
  
- Press MENU 1 / Menu 2.  
The operator panel displays the following message.  
DRUM CNT  
RESET
  
- Press MENU 1 / Menu 2.  
The operator panel displays the following message.  
OP MENU

ENABLE

- Press MENU 1 / Menu 2.

The operator panel displays the following message.

X ADJUST  
0 mm \*

OL410 / OL410e-PS

- Press LAST - / Paper Size or NEXT + / Demo to move through the settings.  
The settings are:

-2.00 -1.75 -1.50 -1.25 -1.00 -0.75 -0.50 -0.25 0  
+0.25 +0.50 +0.75 +1.00 +1.25 +1.50 +1.75 +2.00

*\*An asterisk indicates the current setting.*

- Press ENTER / Copies to select the desired setting.

The operator panel displays the following message.

X ADJUST  
0 mm \*

OL410 / OL410e-PS

*\*An asterisk indicates the current setting.*

- Press ON-LINE to save the setting and exit the user maintenance mode.

The operator panel displays the following message for approximately 15 seconds.

WARM UP

The operator panel displays the following message.

ON-LINE  
HPIIP  
(OL400e)

ON-LINE  
HPIII  
(OL410e)

ON-LINE  
ADOBE PS  
(OL410e/PS)

---

# Y Adjust

---

## Y Adjust

### General Information

This function sets the vertical position of the first printable area (print start position).

Changes are written to the EEPROM.

The print start position is the distance from the leading edge of the paper where printing can begin. Print start positions can vary between printers.

The default is 0.

Negative values of the print start positions move the position closer to the leading edge of the paper.

Positive values of the print start positions move the position away from the leading edge of the paper.

### Procedure

To enable or disable the operator menu, perform the following procedure.

- Close the stacker cover.
- Install the paper cassette tray.
- Clear all error messages displayed on the operator panel.
- Power OFF the unit.
- Press and hold MENU 1 / Menu 2 while powering ON the unit.
  - The operator panel displays the following for approximately two seconds.  
88888888  
88888888
- Release MENU 1 / Menu 2 once the operator panel displays the following message.  
USER MNT
- Press MENU 1 / Menu 2.
  - The operator panel displays the following message.  
MENU  
RESET
- Press MENU 1 / Menu 2.
  - The operator panel displays the following message.  
HEX DUMP
- Press MENU 1 / Menu 2.
  - The operator panel displays the following message.  
DRUM CNT  
RESET
- Press MENU 1 / Menu 2.
  - The operator panel displays the following message.  
OP MENU  
ENABLE
- Press MENU 1 / Menu 2.
  - The operator panel displays the following message.  
X ADJUST  
0 mm \*

OL410 / OL410e-PS

- Press MENU 1 / Menu 2.

The operator panel displays the following message.

Y ADJUST  
0 mm \*

OL410 / OL410e-PS

- Press LAST - / Paper Size or NEXT + / Demo to move through the settings.

The settings are:

-2.00 -1.75 -1.50 -1.25 -1.00 -0.75 -0.50 -0.25 0  
+0.25 +0.50 +0.75 +1.00 +1.25 +1.50 +1.75 +2.00

*\*An asterisk indicates the current setting.*

- Press ENTER / Copies to select the desired setting.

The operator panel displays the following message.

Y ADJUST  
0 mm \*

OL410 / OL410e-PS

*\*An asterisk indicates the current setting.*

- Press ON-LINE to save the setting and exit the user maintenance mode.

The operator panel displays the following message for approximately 15 seconds.

WARM UP

The operator panel displays the following message.

ON-LINE	ON-LINE	ON-LINE
HPIIP	HPIII	ADOBE PS
(OL400e)	(OL410e)	(OL410e/PS)

---



## 3.3.02 System Maintenance Mode

---

### 3.3.02 System Maintenance Mode

NOTE: The end user should NOT access the service maintenance mode.

#### General Information

System maintenance mode allows the service technician to access the following features.

- Page Count Display..... ( )
- Page Count Print Enable/Disable..... ( )
- Continuous Print Test..... ( )
- Serial Loopback Test..... ( )
- EEPROM Reset..... ( )
- EEPROM Reset (Printer Doesn't Initialialize)..... ( )

#### Procedure

To enter the system maintenance mode, perform the following procedure.

- Close the stacker cover.
- Install the paper cassette tray.
- Clear all error messages displayed on the operator panel.
- Power OFF the unit.
- Press and hold RECOVER / Reset while powering ON the unit.
- Continue to hold RECOVER / RESET through both panel displays.
- The operator panel displays the following message for approximately two seconds.  
88888888  
88888888
- Continue to hold RECOVER / RESET until the operator panel displays the following message.  
SYS MNT
- Press MENU 1 / Menu 2.  
The operator panel displays the following message.  
PAGE CNT  
XX
- Press MENU 1 / Menu 2.  
The operator panel displays the following message.  
PAGE PRT  
DISABLE
- Press MENU 1 / Menu 2.  
The operator panel displays the following message.  
CONT PRT
- Press MENU 1 / Menu 2.  
The operator panel displays the following message.  
LOOP TEST
- Press MENU 1 / Menu 2.  
The operator panel displays the following message.  
EEPROM  
RESET
- Press ON-LINE to exit the system maintenance mode.  
The operator panel displays the following message.

ON-LINE  
HPIIP  
(OL400e)

ON-LINE  
HPIII  
(OL410e)

ON-LINE  
ADOBE PS  
(OL410e/PS)

NOTE:

- To work with any of the user maintenance mode items, press ENTER / Copies.
  - Press LAST - / Paper Size or NEXT + / Demo to move through the settings for the user maintenance mode items.
-

# Page Count

---

## Page Count

### General Information

The page count is the total number of pages printed by the unit.

This counter cannot be reset.

The page count is not the same as the drum count or the drum count total.

### Procedure

To view the page count, perform the following procedure.

- Close the stacker cover.
- Install the paper cassette tray.
- Clear all error messages displayed on the operator panel.
- Power OFF the unit.
- Press and hold RECOVER / Reset while powering ON the unit.
- Continue to hold RECOVER / RESET through both panel displays.
- The operator panel displays the following message for approximately two seconds.

88888888

88888888

- Continue to hold RECOVER / RESET until the operator panel displays the following message.

SYS MNT

- Press MENU 1 / Menu 2.

The operator panel displays the following message.

PAGE CNT

XX

*XX = the page count*

- Press ON-LINE to exit the system maintenance mode.

The operator panel displays the following message.

ON-LINE

ON-LINE

ON-LINE

HPIIP

HPIII

ADOBE PS

(OL400e)

(OL410e)

(OL410e/PS)

# Page Count Printing Enable / Disable

---

## Page Count Printing Enable / Disable

### General Information

This function will enable or disable printing the total page count when the menu is printed.

The default is DISABLED.

### Procedure

To print the total page count when the menu is printed, perform the following procedure.

- Close the stacker cover.
- Install the paper cassette tray.
- Clear all error messages displayed on the operator panel.
- Power OFF the unit.
- Press and hold RECOVER / Reset while powering ON the unit.
  
- Continue to hold RECOVER / RESET through both panel displays.  
The operator panel displays the following message for approximately two seconds.  
88888888  
88888888
  
- Continue to hold RECOVER / RESET until the operator panel displays the following message.  
SYS MNT
  
- Press MENU 1 / Menu 2.  
The operator panel displays the following message.  
PAGE CNT  
XX
  
- Press MENU 1 / Menu 2.  
The operator panel displays the following message.  
PAGE PRT  
DISABLE  
*An asterisk will follow the word ENABLE or DISABLE to indicate the selected setting.*
  
- Press the LAST - / Paper Size or NEXT + / Demo to toggle between ENABLE and DISABLE.  
The operator panel displays one of the following messages.  
PAGE PRT    PAGE PRT  
ENABLE      DISABLE  
*An asterisk will follow the word ENABLE or DISABLE to indicate the selected setting.*
  
- Press ENTER / Copies to select ENABLE or DISABLE.  
*An asterisk will follow the word ENABLE or DISABLE to indicate the selected setting.*
  
- Press ON-LINE to save the setting and exit the system maintenance mode  
The operator panel displays the following message for approximately 15 seconds.  
WARM UP  
The operator panel displays the following message.  
ON-LINE      ON-LINE      ON-LINE  
HPIIP        HPIII        ADOBE PS  
(OL400e)    (OL410e)    (OL410e/PS)

# Continuous Print Test

---

## Continuous Print Test

### General Information

The continuous print test allows the service technician to check print quality over an entire page. The unit will print a standard ASCII code pattern, shifting characters one position to the right on subsequent lines.

Print at least five pages of this test before exiting.

When exiting this test, printing will not immediately stop. The print buffer must empty.

### Procedure

To run the continuous print test, perform the following procedure.

- Close the stacker cover.
- Install the paper cassette tray.
- Clear all error messages displayed on the operator panel.
- Power OFF the unit.
- Press and hold RECOVER / Reset while powering ON the unit.
  
- Continue to hold RECOVER / RESET through both panel displays.  
The operator panel displays the following message for approximately two seconds.  
88888888  
88888888
- Continue to hold RECOVER / RESET until the operator panel displays the following message.  
SYS MNT
  
- Press MENU 1 / Menu 2.  
The operator panel displays the following message.  
PAGE CNT  
XX
  
- Press MENU 1 / Menu 2.  
The operator panel displays the following message.  
PAGE PRT  
DISABLE
  
- Press MENU 1 / Menu 2.  
The operator panel displays the following message.  
CONT PRT
  
- Press ENTER / Copies.  
The operator panel displays the following message for approximately 15 seconds.  
WARM UP  
The operator panel displays the following message.  
CONT PRT  
PRINTING
  
- Press ON-LINE to end the continuous print test.  
The operator panel displays the following message.  
CONT PRT  
BROKEN

*Several pages will print after you press ON-LINE. The print buffer must empty.*

- The unit will go ON-LINE.

The operator panel displays the following message.

ON-LINE	ON-LINE	ON-LINE
HPIIP	HPIII	ADOBE PS
(OL400e)	(OL410e)	(OL410e/PS)

---

# Serial Interface Loop Test

## Serial Interface Loop test

### General Information

The serial loop test checks the functions of the serial interface, without connecting the unit to a computer. Data is sent and received through the connector. The test runs independently of the Menu Level 2 interface selection.

### Procedure

To run the serial interface loop test, perform the following procedure.

- Close the stacker cover.
- Install the paper cassette tray.
- Clear all error messages displayed on the operator panel.

You must have one of the following.

- 9 pin loopback test connector
- or
- 9 to 25 pin adapter and 25 pin loopback test connector

- Place the 9 pin loopback test connector or the 9 to 25 pin adapter and 25 pin loopback test connector on the serial port. The configuration is shown below.

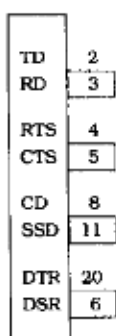

**RS232-C (DB 25P Plug)**

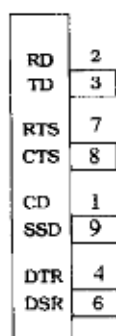

**RS232 (DB 9 P Plug)**

- Press and hold RECOVER / Reset while powering ON the unit.
- Continue to hold RECOVER / RESET through both panel displays.  
The operator panel displays the following message for approximately two seconds.  
88888888  
88888888
- Continue to hold RECOVER / RESET until the operator panel displays...  
SYS MNT
- Press MENU 1 / Menu 2.  
The operator panel displays the following message.  
PAGE CNT  
XX
- Press MENU 1 / Menu 2.  
The operator panel displays the following message.  
PAGE PRT  
DISABLE

- Press MENU 1 / Menu 2.  
The operator panel displays the following message.  
CONT PRT
  
  - Press MENU 1 / Menu 2.  
The operator panel displays the following message.  
LOOP TEST
  
  - Press ENTER / Copies to begin the loopback test.  
If an error occurs during the test, an error message will be displayed  
on the operator panel.  
LOOP ERR  
nnnnn
  
  - Press ON-LINE to end the test.  
The operator panel displays the following message.  
ON-LINE      ON-LINE      ON-LINE  
HPIIP        HPIII        ADOBE PS  
(OL400e)    (OL410e)    (OL410e/PS)
-



## EEPROM Reset (Printer Initializes)

---

### EEPROM Reset (Printer Initializes)

#### CAUTION:

- EEPROM Reset returns ALL EEPROM areas to factory defaults.
- ALL customized menu settings will be lost.
- ALWAYS print the menu before doing an EEPROM reset.

#### General Information

This function resets all EEPROM areas to factory defaults.

This will reset both the menu level 1 and menu level 2 to factory defaults.

ALWAYS print the menu before resetting the EEPROM.

#### Procedure

To reset the EEPROM, perform the following procedure.

- Close the stacker cover.
- Install the paper cassette tray.
- Clear all error messages displayed on the operator panel.
- Power OFF the unit.
- Press and hold RECOVER / Reset while powering ON the unit.
  
- Continue to hold RECOVER / RESET through both panel displays.  
The operator panel displays the following message for approximately two seconds.  
88888888  
88888888
  
- Continue to hold RECOVER / RESET until the operator panel displays the following message.  
SYS MNT
  
- Press MENU 1 / Menu 2.  
The operator panel displays the following message.  
PAGE CNT  
XX
  
- Press MENU 1 / Menu 2.  
The operator panel displays the following message.  
PAGE PRT  
DISABLE
  
- Press MENU 1 / Menu 2.  
The operator panel displays the following message.  
CONT PRT
  
- Press MENU 1 / Menu 2.  
The operator panel displays the following message.  
LOOP TEST
  
- Press MENU 1 / Menu 2.  
The operator panel displays the following message.  
EEPROM  
RESET

- Press ENTER / Copies.

The operator panel displays the following message for approximately 10 seconds  
WARM UP

- The unit will go ON-LINE.

The operator panel displays the following message.

ON-LINE	ON-LINE	ON-LINE
HPIIP	HPIII	ADOBE PS
(OL400e)	(OL410e)	(OL410e/PS)

---

## EEPROM Reset (Printer Does Not Initialize)

---

### EEPROM Reset (Printer Does Not Initialize)

#### CAUTION:

EEPROM Reset returns ALL EEPROM areas to factory defaults.  
ALL customized menu settings will be lost.  
ALWAYS print the menu before doing an EEPROM reset.

#### General Information

This function provides a method for the service technician to reset the EEPROM to factory default values. Use this method should the printer fail to initialize.

#### Procedure

- Close the stacker cover.
  - Install the paper cassette tray.
  - Power OFF the unit.
  - Press and hold the following keys (switches) while powering ON the unit.

USA	MENU and NEXT + / Demo
Europe	Menu and LAST - / Paper Size
Others	Menu and FORM FEED
-

## 3.3.03 Engine Maintenance Mode

---

### 3.3.03 Engine Maintenance Mode

NOTE: The end user should NOT access the engine maintenance mode.

#### General Information

Engine maintenance mode allows the service technician to access the features listed below.

- LED Head Drive Time..... ( )
- Print Start Position..... ( )
- Drum Count Total Display..... ( )
- Drum Count Display..... ( )
- Engine Reset..... ( )
- Factory Adjustment for Second Tray / Multi-Feed  
*Do not change the setting for this feature!*

#### Procedure

To enter the engine maintenance mode, perform the following procedure.

NOTE: Press ENTER / Menu Reset to execute any of the functions being displayed.

To exit from any of the functions being displayed, press ON-LINE.

- Close the stacker cover.
- Install the paper cassette tray.
- Clear all error messages displayed on the operator panel.
- Power OFF the unit.
- Press and hold ENTER / Copies and FORM FEED / Tray Select while powering ON the unit.
- Continue to hold ENTER / COPIES and FORM FEED / Tray Select through all panel displays.
- The operator panel displays the following message for approximately two seconds.  
88888888  
88888888
- The operator panel will briefly display the following message.  
INITIAL-  
IZING
- Continue to hold ENTER / COPIES and FORM FEED / Tray Select until the operator panel displays the following message.  
ENG MNT
- Press MENU 1 / Menu 2.  
The operator panel displays the following message.  
LED HEAD  
NO.16 \*
- Press MENU 1 / Menu 2.  
The operator panel displays the following message.  
PRINT POS  
0 mm \*
- Press MENU 1 / Menu 2.  
The operator panel displays the following message.  
DRUM CNT  
T XX
- Press MENU 1 / Menu 2.  
The operator panel displays the following message.

## DRUM CNT

- Press MENU 1 / Menu 2.  
The operator panel displays the following message.  
T2 TBL1  
No. 3 \*
- Press MENU 1 / Menu 2.  
The operator panel displays the following message.  
T2 TBL2  
No. 3 \*
- Press MENU 1 / Menu 2.  
The operator panel displays the following message.  
EF TBL1  
No. 3 \*
- Press MENU 1 / Menu 2.  
The operator panel displays the following message.  
EF TBL2  
No. 3 \*
- Press MENU 1 / Menu 2.  
The operator panel displays the following message.  
ENGINE  
RESET
- Press ENTER / Menu Reset to execute any of the functions being displayed.
- To change any setting, press LAST - / Paper Size or NEXT + / Demo to move through the settings.

\*An asterisk indicates the current setting.

- Press ENTER / Copies to select the desired setting.

\*An asterisk indicates the current setting.

- Press ON-LINE to save the setting and exit the engine maintenance mode.  
The operator panel displays the following message.  
ON-LINE      ON-LINE      ON-LINE  
HPIIP        HPIII        ADOBE PS  
(OL400e)    (OL410e)    (OL410e/PS)
-

## LED Head Drive Time

### LED Head Drive Time

Note: The LED Drive Table is at the end of this document.

### General Information

This procedure is used to set the LED head drive time. The LED head drive time must be set when the intensity rating of the new LED head is different from the intensity rating of the replaced LED head.

### LED Head Intensity Rating

The last three numbers of the label on the LED head are the LED intensity rating. Use the table below to determine the drive time associated with the intensity rating of the LED head.

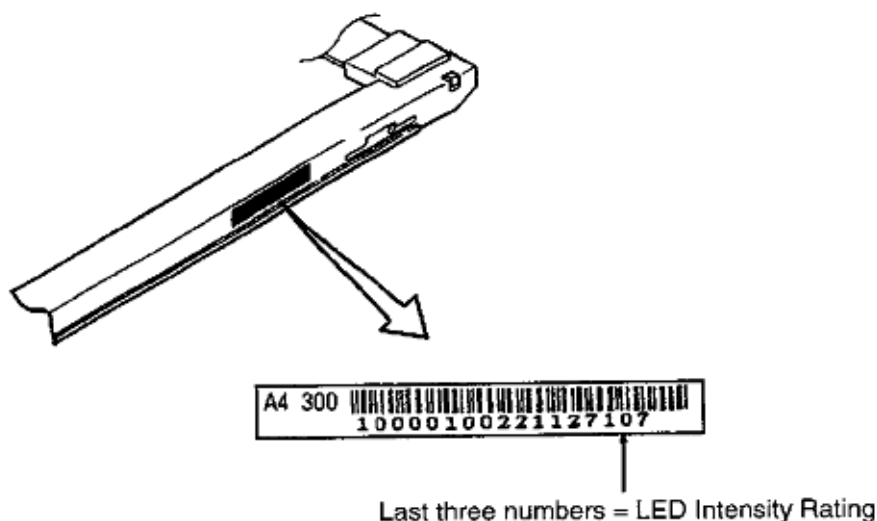

### Procedure

To set the LED Head Drive Time, perform the following procedure.

- Close the stacker cover
- Install the paper cassette tray]
- Clear all error messages displayed on the operator panel.
- Power OFF the unit.
- Press and hold ENTER / Copies and FORM FEED / Tray Select while powering ON the unit.
- Continue to hold ENTER / COPIES and FORM FEED / Tray Select through all panel displays.

The operator panel displays the following message for approximately two seconds.

88888888  
88888888

The operator panel will briefly display the following message.

INITIAL-  
IZING

- Continue to hold ENTER / COPIES and FORM FEED / Tray Select until the operator panel displays the following message.

ENG MNT

- Press MENU 1 / Menu 2.

The operator panel displays the following message.

LED HEAD  
NO.16 \*

- To change the drive time setting, press LAST - / Paper Size or NEXT + / Demo to move through the settings.

*\*An asterisk indicates the current setting.*

Setting values are listed below.

1, 2, 3, 4, 5, 6, 7, 8, 9, 10, 11, 12, 13, 14, 15, 16, 17, 18, 19, 20, 21, 22, 23, 24, 25, 26, 27, 28, 29, 30, 31, 32, 33

- Press ENTER / Copies to select the desired setting.

*\*An asterisk indicates the current setting.*

- Press ON-LINE to save the setting and exit the engine maintenance mode.

The operator panel displays the following message.

ON-LINE	ON-LINE	ON-LINE
HPIIP	HPIII	ADOBE PS
(OL400e)	(OL410e)	(OL410e/PS)

### LED Intensity Rating / Drive Time Table

Label Number (Intensity Rating)	LED Head Drive Time
100 - 104	27
105 - 112	26
113 - 121	25
122 - 131	24
132 - 142	23
143 - 152	22
153 - 167	21
168 - 180	20
181 - 195	19
196 - 211	18
212 - 228	17
229 - 247	16
248 - 269	15
269 - 290	14
291 - 300	13

# Print Start Position

---

## Print Start Position

### General Information

This procedure sets the print start position.

The print start position is the distance from the leading edge of the paper where printing can begin. Print start positions can vary between printers.

The default is 0.

Negative values of the print start positions move the position closer to the leading edge of the paper.

Positive values of the print start positions move the position away from the leading edge of the paper.

### Procedure

To modify the print start position, perform the following procedure.

- Close the stacker cover.
  - Install the paper cassette tray.
  - Clear all error messages displayed on the operator panel.
  - Power OFF the unit.
  
  - Press and hold ENTER / Copies and FORM FEED / Tray Select while powering ON the unit.
  
  - Continue to hold ENTER / COPIES and FORM FEED / Tray Select through all panel displays.
    - The operator panel displays the following message for approximately two seconds.  
88888888  
88888888
    - The operator panel will briefly display the following message.  
INITIAL-  
IZING
  
  - Continue to hold ENTER / COPIES and FORM FEED / Tray Select until the operator panel displays the following message.  
ENG MNT
  
  - Press MENU 1 / Menu 2.
    - The operator panel displays the following message.  
LED HEAD  
NO.16 \*
  
  - Press MENU 1 / Menu 2.
    - The operator panel displays the following message.  
PRINT POS  
0 mm \*
- \*An asterisk indicates the current setting.*

Setting values are in increments of .5 mm  
-4 mm, -3.5 mm, -3 mm, -2.5 mm, -2 mm, -1.5 mm, -1 mm, -.5 mm,  
0 mm, +.5 mm, +1 mm, +1.5 mm, +2 mm, +2.5 mm, 3 mm, 3.5 mm



- Negative values of the print start positions move the position closer to the leading edge of the paper.
- Positive values of the print start positions move the position away from the leading edge of the paper.
  
- To change any setting, press LAST - / Paper Size or NEXT + / Demo to move through the settings.  
*\*An asterisk indicates the current setting.*
  
- Press ENTER / Copies to select the desired setting.  
*\*An asterisk indicates the current setting.*
  
- Press ON-LINE to save the setting and exit the engine maintenance mode.

The operator panel displays the following message.

ON-LINE	ON-LINE	ON-LINE
HPIIP	HPIII	ADOBE PS
(OL400e)	(OL410e)	(OL410e/PS)

---

# Drum Count Total Display

---

## Drum Count Total Display

### General Information

The drum count total display is the total number of revolutions made by the image drum.

For a one page, letter-size print job, the drum rotates five (5) times.

One revolution	=	prepares the drum for printing
Three revolutions	=	print the page
One revolution	=	cleans the drum

The drum count total is NOT the same as the drum count or the page count.

### Procedure

To view the drum count, perform the following procedure.

- Close the stacker cover.
- Install the paper cassette tray.
- Clear all error messages displayed on the operator panel.
- Power OFF the unit.
  
- Press and hold ENTER / Copies and FORM FEED / Tray Select while powering ON the unit.
  
- Continue to hold ENTER / COPIES and FORM FEED / Tray Select through all panel displays.
  - The operator panel displays the following for approximately two seconds.  
88888888  
88888888
  - The operator panel will briefly display the following message.  
INITIAL-  
IZING
  
- Continue to hold ENTER / COPIES and FORM FEED / Tray Select until the operator panel displays the following message.  
ENG MNT
  
- Press MENU 1 / Menu 2.
  - The operator panel displays the following message.  
LED HEAD  
NO.16 \*
- Press MENU 1 / Menu 2.
  - The operator panel displays the following message.  
PRINT POS  
0 mm \*
- Press MENU 1 / Menu 2.
  - The operator panel displays the following message.  
DRUM CNT  
T XX
  
- Press ON-LINE to exit the engine maintenance mode.
  - The operator panel displays the following message.

ON-LINE  
HPIIP  
(OL400e)

ON-LINE  
HPIII  
(OL410e)

ON-LINE  
ADOBE PS  
(OL410e/PS)

---

# Drum Count

---

## Drum Count

### General Information

The drum count is a calculation based on the number of rotations of the image drum.

It is NOT the same as the drum count total or the page count.

### Procedure

To view the drum count, perform the following procedure.

- Close the stacker cover.
- Install the paper cassette tray.
- Clear all error messages displayed on the operator panel.
- Power OFF the unit.
  
- Press and hold ENTER / Copies and FORM FEED / Tray Select while powering ON the unit.
  
- Continue to hold ENTER / COPIES and FORM FEED / Tray Select through all panel displays.
  - The operator panel displays the following for approximately two seconds.  
88888888  
88888888
  - The operator panel will briefly display the following message.  
INITIAL-  
IZING
  
- Continue to hold ENTER / COPIES and FORM FEED / Tray Select until the operator panel displays the following message.  
ENG MNT
  
- Press MENU 1 / Menu 2.
  - The operator panel displays the following message.  
LED HEAD  
NO.16 \*
- Press MENU 1 / Menu 2.
  - The operator panel displays the following message.  
PRINT POS  
0 mm \*
- Press MENU 1 / Menu 2.
  - The operator panel displays the following message.  
DRUM CNT  
T XX
  
- Press MENU 1 / Menu 2.
  - The operator panel displays the following message.  
DRUM CNT  
XX
  
- Press ON-LINE to exit the engine maintenance mode.
  - The operator panel displays the following message.  
ON-LINE      ON-LINE      ON-LINE  
HPIIP        HPIII        ADOBE PS  
(OL400e)    (OL410e)    (OL410e/PS)

## T2 Tbl 1

---

### T2 TBL 1

#### General Information

This function is set at the factory.  
Settings are 1, 2, and 3.  
The factory setting is 3.

Do NOT change the setting!

---

## T2 Tbl 2

---

### T2 TBL 2

#### General Information

This function is set at the factory.  
Settings are 1, 2, and 3.  
The factory setting is 3.

Do NOT change the setting!

---

## EF Tbl 1

---

### EF TBL 1

#### **General Information**

This function is set at the factory.  
Settings are 1, 2, and 3.  
The factory setting is 3.

Do NOT change the setting!

---

## EF Tbl 2

---

### EF TBL 2

#### **General Information**

This function is set at the factory.  
Settings are 1, 2, and 3.  
The factory setting is 3.

Do NOT change the setting!

---



# Engine Reset

---

## Engine Reset

### General Information

This function resets the EEPROM to factory defaults.

Resetting the engine does NOT affect menu level 1, menu level 2, operator panel menu enable / disable, and page print disable / enable.

### Procedure

To enter the engine maintenance mode, perform the following procedure.

- Close the stacker cover.
- Install the paper cassette tray.
- Clear all error messages displayed on the operator panel.
- Power OFF the unit.
- Press and hold ENTER / Copies and FORM FEED / Tray Select while powering ON the unit.
- Continue to hold ENTER / COPIES and FORM FEED / Tray Select through all panel displays.
  
- The operator panel displays the following message for approximately two seconds.  
88888888  
88888888
  
- The operator panel will briefly display the following message.  
INITIAL-  
IZING
  
- Continue to hold ENTER / COPIES and FORM FEED / Tray Select until the operator panel displays the following message.  
ENG MNT
  
- Press MENU 1 / Menu 2.  
The operator panel displays the following message.  
LED HEAD  
NO.16 \*
  
- Press MENU 1 / Menu 2.  
The operator panel displays the following message.  
PRINT POS  
0 mm \*
  
- Press MENU 1 / Menu 2.  
The operator panel displays the following message.  
DRUM CNT  
T XX
  
- Press MENU 1 / Menu 2.  
The operator panel displays the following message.  
DRUM CNT

- Press MENU 1 / Menu 2.  
The operator panel displays the following message.  
T2 TBL1  
No. 3 \*
  
  - Press MENU 1 / Menu 2.  
The operator panel displays the following message.  
T2 TBL2  
No. 3 \*
  
  - Press MENU 1 / Menu 2.  
The operator panel displays the following message.  
EF TBL1  
No. 3 \*
  
  - Press MENU 1 / Menu 2.  
The operator panel displays the following message.  
EF TBL2  
No. 3 \*
  
  - Press MENU 1 / Menu 2.  
The operator panel displays the following message.  
ENGINE  
RESET
  
  - Press ENTER / Copies.  
The operator panel displays the following message.  
ENGINE  
RESETTING
  
  - When the reset is complete, the unit will go ON-LINE.  
The operator panel displays the following message.  
ON-LINE      ON-LINE      ON-LINE  
HPIIP        HPIII        ADOBE PS  
(OL400e)    (OL410e)    (OL410e/PS)
-

## 3.4 Cleaning General Information

---

### 3.4 CLEANING

#### General Information

- Routine inspection and cleaning should be performed every six months.
- Remove any dropped toner and dust.
- Clean inside and around the printer with a vacuum cleaner (designed to pick-up toner) when necessary.

#### CAUTION:

If you use a vacuum cleaner that does not have a toner filter, you may severely damage the vacuum cleaner.

Do not touch the transfer roller! Touching the transfer roller may cause incomplete toner transfer, resulting in faded output.

---

## 3.4.02 Printer Unit

---

### 3.4.02 Printer Unit

Clean the inside of the unit with a vacuum cleaner designed to handle toner.

If you use a vacuum cleaner that does not have a toner filter, you may severely damage the vacuum cleaner.

Be sure to thoroughly vacuum around all sensors.

**CAUTION:**

**Do not touch the transfer roller! ! !**

**Touching the transfer roller may cause incomplete toner transfer, resulting in faded output.**

---

### **3.4.03 Covers**

---

#### **3.4.03 Covers**

Clean the covers using a soft, lint-free cloth and an all-purpose cleaner.

---

## 3.4.04 LED Head Unit

---

### 3.4.04 LED Head Unit

Note: The information in this section is also covered in TSB 5616([link](#)). Refer to Section 4 of this Service Handbook for additional troubleshooting information.

The LED head unit should be cleaned when any of the following occur.

- A new toner cartridge is installed.
- Vertical white lines or stripes (voids and/or light printing) appear on the output.
- Light print
- "Spotchy" print
- Fuzzy print
- White "spots" where there should be black

**To clean the LED head, follow either of these procedures.**

#### LED Lens Cleaner Pad

- Use the cleaning pad supplied in the toner cartridge kit.
- Slide the cleaner pad across the lens array several times to clean the head. Use a clean portion of the pad each pass.
- Discard the used pad.

#### Isopropyl Alcohol

- Locate a soft cotton swab.
- Locate isopropyl alcohol (90%). Follow all direction and cautions for use on the container.
- Apply a small amount of alcohol to the cotton swab.
- Gently move the swab across the face of the LED lens.
- Use a clean section of the swab on each pass.
- Move the swab in one direction.
- Lift the swab from the lens surface between each pass.
- Apply ONLY enough pressure to remove loose toner. DO NOT scrub or scratch the LED.

DO NOT allow alcohol to spill or drip inside the printer, on any components, or onto the image drum.

---

## 3.4.05 Cleaning Cycle Initialization

---

### 3.4.05 Cleaning Cycle Initialization

- The information in this section is also covered in TSB 5612 (□).
- Refer to Section 4 (□) of this Service Handbook for additional troubleshooting information.

The cleaning cycle clears the image drum of unused toner.

The cleaning cycle occurs on request (manual initialization) and automatically.

During a manual initialization of the cycle, a page is run through the paper feed mechanism. The polarity of the rollers is reversed. This page will attract any excess toner and paper debris left on the rollers of the printer. When the page is ejected, it should be discarded. The printer can be placed ON-LINE. Normal operation can be resumed.

The automatic cleaning cycle occurs after every tenth printed page. The automatic cleaning cycle does not cause a page to be ejected. This cycle reverses the polarity of the rollers. This helps keep the rollers clean.

The cleaning cycle should be initiated when any of the following occur.

- Gray background on output
- Shading concerns during printing

#### **Procedure**

To initiate the cleaning cycle, perform the following procedure.

- Close the stacker cover.
  - Install the paper cassette tray.
  - Clear all error messages displayed on the operator panel.
  - Power OFF the unit.
  - Power ON the unit.
  - Place the printer OFF-LINE
  - Press LAST - / Paper Size and NEXT + / Demo simultaneously.
  - The printer runs a page through the paper feed mechanism.
  - The page is ejected.
  - Discard the page.
  - Place the unit ON-LINE.
  - Resume normal operation.
-

## 3.5 Lubrication General Information

---

### 3.5 LUBRICATION General Information

Lubrication should be performed once a year or as needed.

Use Dow Corning Molycoat BR-2 or Molycoat ME-300L or equivalent.

Use very small amounts of lubricant when applying. DO NOT over-lubricate.

DO NOT allow lubricant to contact the surface of any rollers or paper guides.

Lubricate the items listed in the table below.

Lubrication Table

Item	Disassembly Procedure
Gear on the shaft of the main stepper motor	3.2.09 (📄)
Gear on the shaft of the registration stepper motor	3.2.10 (📄)
Teeth of the reduction gear	3.2.12 (📄)
Inside of bearings of hopping roller shaft assembly	3.2.13 (📄)
Hopping roller shaft, above the fins	3.2.13 (📄)
Inside of the pivot points of the reset levers	3.2.14 (📄)
Gear on the damper stacker arm	3.2.14 (📄)
Stacker cover damper gear	3.2.14 (📄)
Transfer roller gear	3.2.16 (📄)
Inside of bearings of transfer roller	3.2.16 (📄)
Ends of pressure roller shaft	3.2.18 (📄)

---



## 3.6 Shipping Instructions - Return For Service

---

### 3.6 SHIPPING INSTRUCTIONS - Return for Service

CAUTION: When shipping the printer, use the original foam packaging to prevent damage.

A "toner bomb" (severe toner spillage) WILL OCCUR if the image drum is not properly packaged for shipping.

Okidata charges a cleaning fee for ALL products sent in for service and received by Okidata with a "toner bomb" condition.

If the shipping instructions are NOT followed, Okidata may levy a surcharge against the dealership.

Locate the original foam packaging or order replacement packaging from Okidata.

- Remove the image drum cartridge.
  - Place the image drum into a black plastic velostat bag. (Refer to Appendix B())
  - Store the image drum cartridge in a safe place, away from sunlight. Install the drum when the printer is returned.
  - Pack the unit, using the materials from Step 1.
-

## 3.6.02 All Other Returns

---

### 3.6.02 All Other Returns

CAUTION: The product MUST be returned in the original packaging.  
The product MUST be returned with ALL originally supplied factory items.

A "toner bomb" (severe toner spillage) WILL OCCUR if the image drum is not properly packaged for shipping.

Okidata charges a cleaning fee for ALL products sent in for service and received by Okidata with a "toner bomb" condition.

If the shipping instructions are NOT followed, Okidata may levy a surcharge against the dealership.

- Locate the original foam packaging or order replacement packaging from Okidata.  
(Refer to Appendix B (□))
- Locate the originally supplied factory items.  
(Refer to Setting Up in the Printer Handbook)
- Remove the image drum cartridge, with the toner cartridge installed.
- Place the image drum into the black plastic bag (part of the original packaging).  
(Refer to Appendix B (□))
- Install the image drum into the printer.
- Fold over the opening of the black plastic bag twice.
- Tape the fold close.
- Gently close the stacker cover.
- Pack the unit, using the materials from Step 1.
- Pack the items listed below.
- Software support diskette
- Printer Handbook(s)
- Power Cord

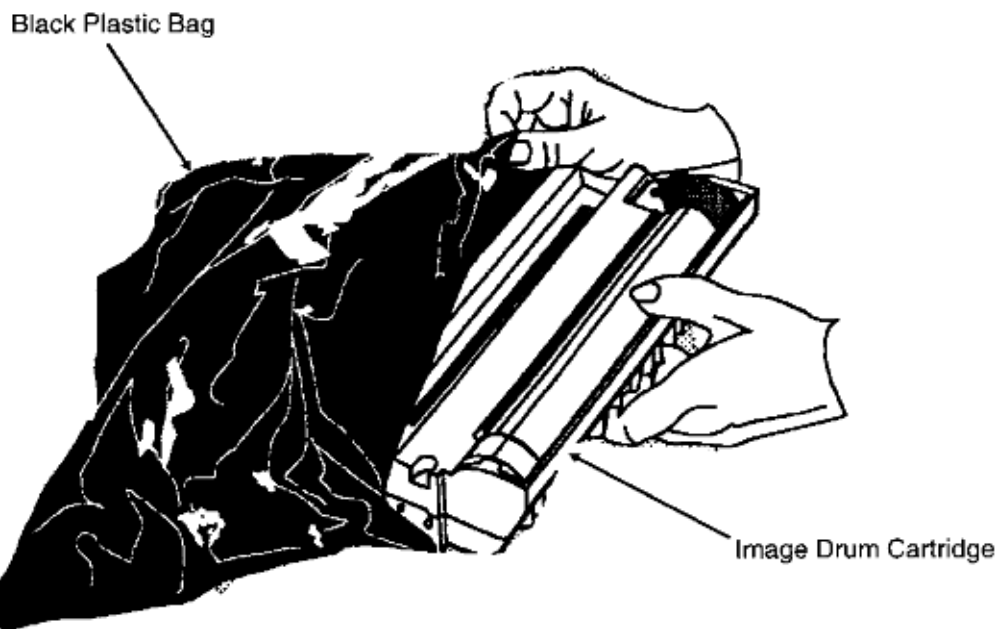
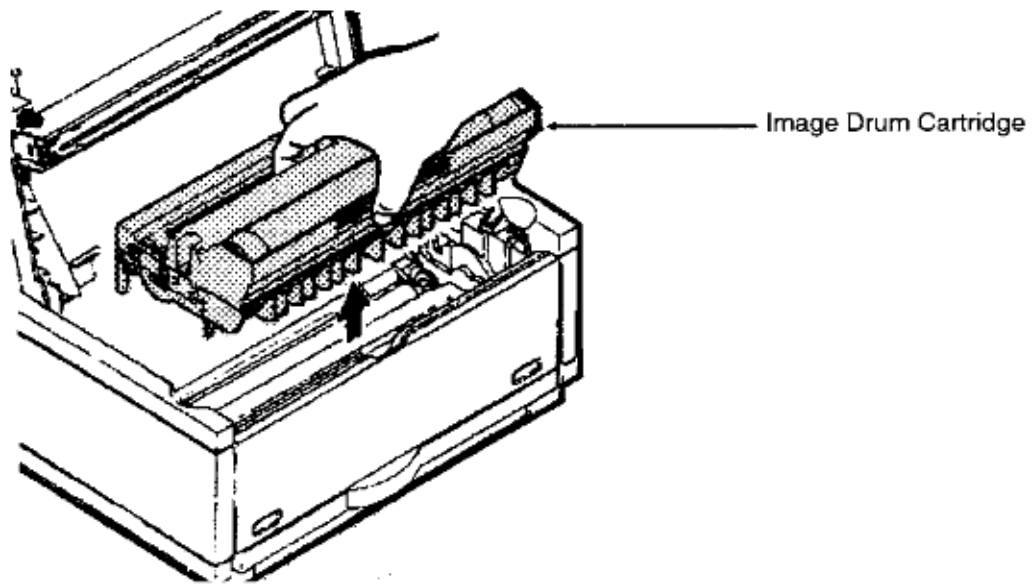

# Chapter 4

## 4.1.01 Troubleshooting Steps

---

### 4.1.01 Introduction

This section is used to isolate problems to the assembly level. Application problems and detection of faulty components on the printed circuit boards are NOT addressed.

When troubleshooting a defective unit, follow these steps.

- 1) Refer to Section 4.3 (📄), which explains where to check for updates to the troubleshooting information.
  - 2) Section 4.4 (📄) contains tips on preventing problems, as well as a list of common problems.
  - 3) Section 4.5 (📄) shows samples of abnormal outputs.
  - 4) Section 4.6 (📄) provides tables of error messages.
  - 5) Section 4.7 (📄) contains the Repair Analysis Procedures (RAPs). Each RAP will ask you questions or require you to make observations. The answers to these questions and the results of your observations determine your next course of action. Use the RAP Index to identify which RAP should be used to resolve the problem with the machine.
  - 6) Section 4.8 (📄) provides the procedures for various printer tests.
  - 7) Section 4.9 (📄) lists the resistance check points.
  - 8) Section 4.2 (📄) lists methods for reporting problems. If you encounter a situation that is NOT addressed by the documentation in this kit, please report the problem to Okidata, using one of the methods listed.
  - 9) Refer to the Service Center Reference Guide for information on contacting Okidata.
-

## 4.2 Reporting Problems - General Information

---

### 4.2 REPORTING PROBLEMS - General Information

Okidata strives to provide accurate and detailed service information through its training materials. The Technical Training Group realizes that service technicians have valuable experience, knowledge, and opinions. Okidata strongly encourages you to report any problems you may encounter when using the materials of this training kit. Please be as specific and detailed as possible. Your comments, suggestions, and criticisms are used to update and revise training kits.

You should reference the training materials when servicing Okidata products. Most problems can be solved by using the information provided in the training materials. If you encounter a situation that cannot be solved, please let Okidata know.

Refer to the Service Center Reference Guide for information on contacting Okidata.

#### Problem Lists

Technicians frequently request a list of common problems specific to a product. Technical Training Kits are written before a product is shipped to customers. Therefore, such information is NOT available when a product is first released.

However, Okidata wants to respond to these requests. **Okilink II** provides round-table discussions on technical problems. Errors and corrections in the training materials are listed in the Training Section of Okilink II. The **Technical Service Bulletins** (also known as Okidata's Monthly Mail) are available via Okilink II. Situations that are NOT addressed in the reference documentation, technical service bulletins, or round-tables may be reported to the Dealer Service and Support Engineers (Contact Technical Support) or the Technical Training Group. You will receive a response to your message within one business day.

The information on Okilink II is the most accurate and up-to-date technical information available from Okidata. This is only possible with your assistance. By reporting your suggestions, concerns, and problems, Okidata can provide the best possible information.

*Your cooperation is greatly appreciated. Thank you for your help!*

#### Reporting Methods

##### Okilink II

You may use Okilink II to report your findings. Refer to the Service Center Reference Guide for information on using Okilink II.

##### Course Critique

Use the Course Critique to report any problems you find as you are completing the self-paced training.

##### Fax Number

If you wish to fax your response, please use the numbers listed in the Service Center Reference Guide.

### Mailing Address

If you respond by mail, please use the appropriate address listed in the Service Center Reference Guide.

### Information Provided

Please provide the following information when reporting problems.

- Okidata Dealer Number
  - Technician's Name
  - Company Name
  - Company's Address (Street, City, State/Province, ZIP / Postal Code, Country)
  - Telephone and Fax Numbers (with area / country access codes)
  - Product Name
  - Unit's Serial Number
  - Firmware Revision Level
  - Description of Problem
  - Document Name (with page number or procedure) with error or problem.
-

## 4.3 Troubleshooting Updates

---

### 4.3 TROUBLESHOOTING UPDATES

#### General Information

Okidata distributes updated troubleshooting information in three ways.

- Okilink II
- Faxable Facts
- Technical Service Bulletins

#### Okilink II

Okilink II is Okidata's Bulletin Board Service. This service is available to all Okidata Certified Service Technicians. Okilink II provides troubleshooting and service information. Technicians can download files, ask questions of Okidata's technical support personnel, and participate in round table discussions about Okidata products and services. Technical Service Bulletins, Recommended Spare Parts Lists, Printer Drivers, Product Specifications, and Service Training Information are also available.

Refer to the Service Center Reference Guide for information on accessing Okilink II.

#### Faxable Facts

Okidata's Faxable Facts is an automated fax document retrieval system. It is maintained by Okidata's Customer Information Center. Answers to common questions about Okidata products are available through Faxable Facts.

Refer to the Service Center Reference Guide for information on accessing Faxable Facts.

#### Technical Service Bulletins

Okidata's Technical Service Bulletins (TSBs) contain technical information developed after product release. Firmware updates, part number changes, and procedural changes are some of the subjects covered by these bulletins. The TSBs are distributed through Okilink II.

Refer to the Service Center Reference Guide for information on accessing Okilink II.

---

## 4.4 Troubleshooting Tips - Preliminary Checks

---

### 4.4 TROUBLESHOOTING TIPS - Preliminary Checks

#### Preliminary Checks

- Is the printer operated under the proper ambient conditions?
  - Is the paper being used made specifically for xerographic printing?
  - Have the toner cartridge and image drum been replaced as recommended?
  - Has the image drum cartridge been installed properly?
  - Are the correct software printer drivers being used?
  - Is OKIDATA toner being used?
-



## 4.4.02 Tips For Preventing Image Problems

---

### 4.4.02 Tips for Preventing Image Problems

- Do not let anything touch the surface of the image drum.
  - NEVER expose the image drum to direct sunlight.
  - Do not touch the fusing unit. Oil from your skin can cause fusing temperature variation.
  - Do not expose the image drum to light for more than five minutes.
-

## \*4.4.03 Common Problems

---

### 4.4.03 Common Problems

#### **A "TONER SNS" or "TONER LOW" message appears on a new printer.**

Customers may experience a "TONER SNS" or "TONER LOW" message with a brand new printer. This may occur even though a new toner cartridge and drum have been installed.

This can occur for the first 30 pages. Between 30 and 200 pages, the CPU will turn OFF the toner sensor. This will eliminate the message on the LCD. After 200 pages, the printer will begin checking for proper operation of the toner sensor flag.

Customers should use the printers for at least 30 pages. The "TONER SNS" or "TONER LOW" messages do not cause any print quality problems. The unit is in NO danger of suffering any damage. If the problem persists for more than thirty pages, customers are directed to contact a service center for warranty repair.

This information is provided in Technical Service Bulletin 5604 ().

#### **The unit appears to be without power.**

If the operator panel or the operator panel cable are not properly attached, the unit will appear to be completely without power.

Symptoms include: no operator panel display, no power to the fan, no movement of the motors or gears, and no lighting of the fuser lamp.

The symptoms usually occur after the upper cover of the printer has been removed and then replaced (repairs, firmware upgrades, etc.).

The symptoms may also occur if the operator panel is dislodged by the end user.

The operator panel cable can be easily damaged during the removal and installation of the upper cover. Dislodging, cutting, and/or crimping of the cable can occur if the technician does not follow the disassembly procedure for the upper cover (Section 3 of this Service Handbook).

When diagnosing initialization failures, refer to RAP 1 (📄) of this Service Handbook.

This information is provided in Technical Service Bulletin 5605.

#### **The unit makes a tapping noise when the fan is running.**

The noise is only apparent in quiet environments and does not exist on all OL4xxe printers.

To correct the problem, remove the small piece of foam located inside the upper cover of the printer. The foam is glued to the cover, just behind the fan. Be careful not to damage the upper cover when removing the foam.

Follow the disassembly procedure (Section 3 of this Service Handbook) for removing the upper cover.

Power ON the unit to verify that the problem has been corrected.

If the noise is still heard, loosen the upper cover screws and slightly shift the cover towards the back (rear) of the printer.

Tighten the screws.

The noise should stop.

This information is provided in Technical Service Bulletin 5606.

**The printer feeds between 100 - 150 pages. Then, pages won't feed.**

Check the feed rollers. Is a slick film present on the rollers?

If yes, check the type of paper being fed. Paper with a high cotton content will coat the rollers with cotton fibers. The fibers make the rollers "slick" and paper will not feed.

Clean the rollers with water.

Cotton free or low cotton content (25% or less) should be used.

**ERROR 05 9FC2160C appears on the operator panel when printing either the menu or print fonts.**

This occurs when either the menu or print fonts is run after a demo page is printed.

This problem is related to the firmware.

Firmware revision 2.14 (or later) will correct the problem.

**The paper tray will NOT stay in the unit.**

Check the two tabs in the base assembly.

These tabs hold the paper tray in place.

If they are broken, replace the left and right cassette guides.

---

## **\*4.4.04 Audible Roller Noises**

---

### **4.4.04 Audible Roller Noises**

NOTE: The information in this section is also covered in TSB 5608 / FCO 8126.

#### **Symptoms**

The unit "squeaks and squeals" whenever the rollers in the unit are turning.

#### **Cause**

The copper frame ground clip of the fuser pressure roller requires lubrication.

When viewing the printer from the front, the clip is on the right hand side.

#### **Solution**

Lubricate the clip.

To access the clip, disassemble the unit to the fusing unit assembly.

Refer to Section Three of this Service Handbook for disassembly information.

Apply a very small amount of Dow Corning Molykote HP 300 grease to the face of the ground clip, where the clip contact the fuser pressure roller.

DO NOT OVER LUBRICATE. Excess lubricant will attract toner and could cause problems.

#### **Assemble the unit.**

Okidata FCO Kit 8126 (P/N 58235401) includes the grease and instructional diagrams. Each kit contains enough grease for many applications.

---

## **\*4.4.05 Audible Noise / Input Jams From Paper Cassette**

---

### **4.4.05 Audible Noise / Input Jams from Paper Cassette**

NOTE: The information in this section is also covered in TSB 5609 / FCO 8127.

#### **Symptoms**

The unit "squeaks and groans" when paper is fed into the printer.

Paper jams when being fed from the paper cassette.

#### **Cause**

The paper separator frame inside the paper cassette.

"Squeaks" are caused by the paper separator frame rubbing against the paper cassette.

"Groans" are caused by the separation rubber of the paper separator frame. The separation rubber is either deformed or does not fit properly.

#### **Solution**

Okidata FCO Kit 8127 (P/N 58235501).

This kit includes grease, a spring, a separation rubber, TSB 5609, and an installation instruction sheet.

The grease lubricates the assembly.

The spring provides more side to side pressure.

The separation rubber is trimmed to a more appropriate size. It is also more securely attached to the new paper separator frame.

Remove the paper cassette and follow the instructions in the FCO Kit 8127.

---

## \*4.4.06 Pinch Roller Clip Problems

---

### 4.4.06 Pinch Roller Clip Problems

NOTE: The information in this section is also covered in TSB 5613.

#### Symptoms

- Paper Feed Jams
- Paper jams occur at or near the registration roller.
- The leading edge of the paper (in most cases) stops under the drum unit.
- Print Registration Errors
- The printed page does not begin at the top of form.
- In some cases, the print shifts down from the top of the page.
- Print Skewing
- Printed pages may be visible skewed.
- To verify, follow this procedure.
- Load paper in the cassette.
- Take the printer OFF-LINE.
- Press PRINT FONTS.
- The Print Fonts Test will print.
- This test will dramatically show the skew, if it is present.

#### Cause

This problem is caused by a misalignment of the pinch roller clips on version B8 image drums. The pinch rollers on the bottom of the drum unit provide the pressure needed to move the paper evenly through the registration rollers. Misalignment is caused when the retaining clip slightly rotates towards the pinch roller. The pinch roller is normally level, but a rotated clip will tilt the roller. Because of the tilt of the pinch roller, uneven pressure will be applied to the registration roller. (Note the space between the edge of the retaining clip and the drum's outer ribbing. Refer to the diagram.) Rough handling during shipping may cause the retaining clips to rotate.

To identify a version B8 image drum, look at the white label on the left leading edge of the drum. The first two characters of the drum lot number are the version.

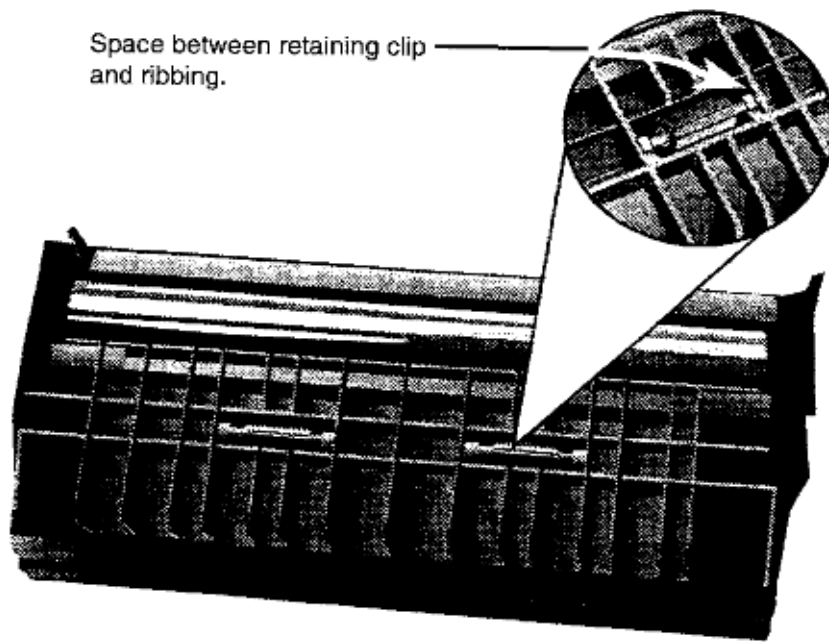

Space between retaining clip and ribbing.

### **Solution**

To correct this problem, follow this procedure.

- Remove the image drum unit from the printer.
- Turn the drum so the pinch rollers face up.
  - Be careful NOT to spill toner.
  - Do NOT touch the surface of the drum.
  - Touching the drum may cause permanent damage to the drum's surface.
- Use a pair of needle-nose pliers to press the retaining clip against the plastic ribbing closest to the clip. If done correctly, there will little or no space between the retainer clip and the plastic rib.
- Repeat the process until all four clips have been levelled.
- Place the drum back into the printer.
- Test the printer by running the Print Fonts Test.
  - Load paper in the cassette.
  - Take the printer OFF-LINE.
  - Press PRINT FONTS.
  - The Print Fonts Test will print.

*This test will dramatically show the skew, if it is present.*

- If the problem still occurs, the image drum unit may need to be replaced or the printer may be experiencing a different failure.

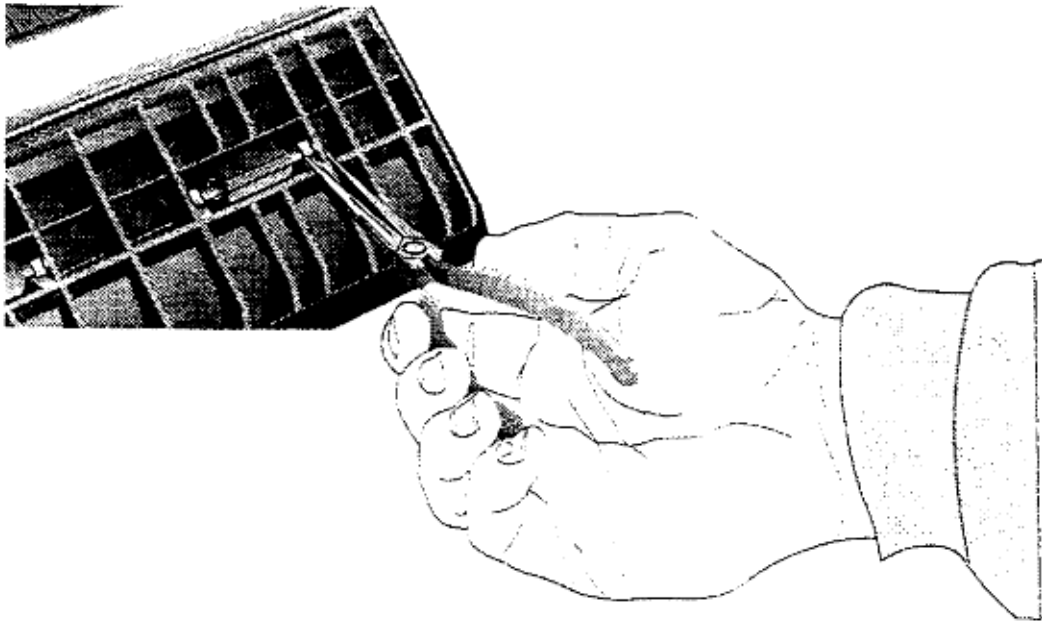



## \*4.4.07 Paper Jams Under The Fuser Roller

---

### 4.4.07 Paper Jams Under the Fuser Roller

NOTE: The information in this section is also covered in TSB 5614 / FCO 8172.

#### Symptoms

The paper jams under the fuser roller and must be removed by a technician.

The leading edge of the paper is stuck in the area of the paper exit lever.

The rest of the page "bunches up" under the fuser roller.

The end user cannot remove the paper. Not enough paper is visible/available for the end user to grasp and remove.

#### Solution

Install the recommended exit sensor lever assembly and/or firmware (listed below).

Lever: Exit Sensor (Assembly) P/N 51010802

Firmware (OL400e) P/N 31097905  
Self-Test Revision Number 3.03 or higher.

Firmware (OL410e) P/N 31098302  
Self-Test Revision Number 2.0 or higher.

Some printers may require only sensor levers. Some may require only firmware.

Check the Self-Test Revision Number BEFORE changing the firmware. The printer may already include the recommended firmware.

Printers with serial numbers HIGHER than those listed below will require the installation of the recommended firmware. The recommended sensor is already installed.

OL400e 120 volt 310A0086272

OL400e 2XX volt 310A0000245

OL410e 120 volt 308A0005201

OL410e 2XX volt 312A0000129

ALL printers with a serial number 404xxxxxxx include both the recommended sensor and the recommended firmware.

The recommended exit sensor lever assembly does not "catch" the leading edge of the paper.

This part is installed in place of the Plate: Sensor Outlet. To reach the part, the lower base must be removed. Refer to Section 3 for disassembly procedures.

The recommended firmware changes the timing of the paper jam signal to prevent the paper jam and allows more paper to be available to the user to grasp and remove. Users will be able to clear the jam without calling for service.

The firmware is located on the main controller board.

---

## 4.4.08 Dirty LED

---

### 4.4.08 Dirty LED

NOTE:

The information in this section is also covered in TSB 5616.

Refer to Section 3 of this Service Handbook for more cleaning information.

#### **Symptoms**

Light print

"Splotchy" print

Fuzzy print

White "spots" where there should be black

#### **Solutions**

Clean the LED every time the toner cartridge is changed.

Use the LED lens cleaner pad included with the new toner cartridge.

A lens cleaner pad may not always be available. The LED may be cleaned by following the procedure listed below.

- Locate a soft cotton swab.
- Locate isopropyl alcohol (90%). Follow all direction and cautions for use on the container.
- Apply a small amount of alcohol to the cotton swab.
- Gently move the swab across the face of the LED lens.
  - Use a clean section of the swab on each pass.
  - Move the swab in one direction.
  - Lift the swab from the lens surface between each pass.
- Apply ONLY enough pressure to remove loose toner. DO NOT scrub or scratch the LED.
- DO NOT allow alcohol to spill or drip inside the printer, on any components, or onto the image drum.

## 4.5 Abnormal Output - Output Samples & Repair Procedures

---

### 4.5 ABNORMAL OUTPUT - Output Samples



Light or faded output  
Refer to RAP 08  
Refer to RAP 10



Black output  
Refer to RAP 09

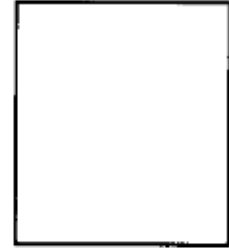

Blank output



Vertical black streaks  
Refer to RAP 11  
Refer to RAP 15

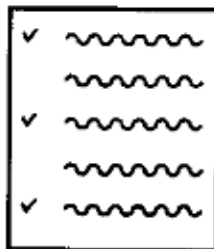

Missing output  
Refer to RAP 13



Vertical white

### Preliminary Checks

The OL4xxe printers will experience poor print quality if the image drum area is not kept clean. It is very important to clean the contact assembly in this area.

When viewing the printer from the front, the contact assembly is on the left. Refer to the diagram for reference points.

Use Contact Kleen (P/N 51802301) to clean the contacts.

The information on these pages is provided in Technical Service Bulletin 5607.

### Overall Light Print

Clean contacts 3 and 5.

Verify that the toner supply is adequate.

Verify that the Menu Darkness setting is appropriate.

Refer to RAP 08.

**Black Page**

Clean contact number 6.

Refer to RAP 09.

**Gray Shading or Banding**

Clean contacts 1 and 2.

Verify that no toner is spilled.

Verify that the drum is good.

Refer to RAP 09.

**Black Dots Or Specks**

Clean contacts 1 and 3.

Verify that no toner is spilled

Verify that the drum is good.

Refer to RAP 11.

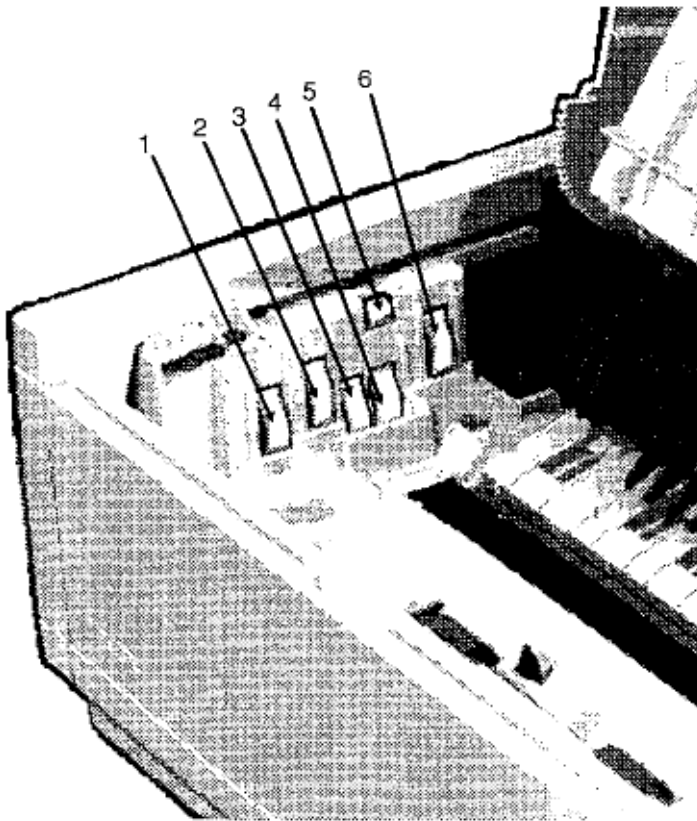

## 4.6 Error Messages - Using The Error Message Charts

---

### 4.6 ERROR MESSAGES - Using the Error Message Charts

The Error Message Charts provide the information listed below.

- Message displayed on operator panel
- Description of the error message
- Possible solution to the problem

The major groups of error messages are listed below.

- Daily Status
  - Paper Messages
  - Cover Open
  - Buffer Overflow Errors
  - Interface Errors
  - Paper Size Errors
  - Jam Errors
  - EEPROM Errors
  - ROM Errors
  - Card Errors
  - Controller Errors
  - OL410e/PS Messages
-

## Front Panel Messages: Normal Daily Status

---

### Front Panel Messages: Normal Daily Status

Category	LCD Message	Problem	Solution
Daily Status	ON-LINE HP IIP	The printer is ON-LINE.  READY lit:The printer is ON-LINE.  READY flashing:The printer is going from ON-LINE to OFF-LIN	Normal operation
Daily Status	OFF-LINE (LED is NOT lit)	The printer is OFF-LINE.	The printer is OFF-LINE.
The printer is OFF-LINE.	DATA	The printer is ON-LINE and data is being processed.  READY lit:Unprinted data is in the buffer.READY flashing:Data is being received.	Normal operation
Daily Status	HP II P	Displayed below first line messages.  Indicates the current printer emulation.	Normal operation
Daily Status	HEX DUMP	Displayed below first line messages.  Indicates Hex Dump Mode.	Normal operation
Daily Status	CPYnn/mm	Displayed below first line messages.The number of copies being printed is displayed (two or more).	Normal operation

Daily Status	PWR SAVE	<p>Displayed below first line messages.</p> <p>The printer is in the power save mode.</p>	Normal operation
Daily Status	TONERLOW	<p>Displayed below first line messages.</p> <p>Toner is running out. Printing can be stopped, or normal operation can be continued.</p>	Replace the toner cartridge.
Daily Status	CHG DRUM	<p>Displayed below first line messages.</p> <p>A fault occurred in the toner sensor.</p> <p>Printing can be stopped, or normal operation can continue.</p>	<p>Replace the image drum cartridge</p> <p>After replacing the image drum cartridge, reset the drum counter.</p>
Daily Status	TONERSNS	<p>Displayed below first line messages.</p> <p>A fault occurred in the toner sensor.</p> <p>Printing can be stopped, or normal operation can continue.</p>	<p>Replace the image drum cartridge. Replace the power supply board.</p>
Daily Status	##### LED blinking	<p>Displayed below first line messages.</p> <p>##### represents the message registered by the LCD down load command.</p>	
Daily Status	PRINT DEMO LED blinking	<p>The demo page is being printed.</p> <p>READY flashing: Executed by key operation.</p>	



Daily Status	PRINTMENU	The current menu settings are being printed.READY lit:Executed by commandREADY flashing:Executed by switch	
Daily Status	PRINT FONTS LED blinking	The installed fonts are being printed.	
Daily Status	PRINT CLEANING LED blinking	The print cleaning process is being executed.	
Daily Status	PRINTING HP II P	The printer is printing.	
Daily Status	WARM UP	The printer is warming-up.After warming up is completed, the printer will go ON-LINE.After initialization, the printer becomes ready to receive data	
Daily Status	88888888 88888888	This message is displayed at power ON.  When the printer is powered ON, the LED is lit for about 1 second to check the operation of the LED and LCD.	Normal Operation
Daily Status	INITIAL -IZING (LED is NOT lit)	This message is displayed during power ON. The controller is being initialized. This message is displayed after the LED is lit.	Normal Operation

Daily Status	RESET (LED is NOT lit)	The data that remains in the buffer is deleted and the printer is initialized to default settings. The temporary DLLs and macros are deleted.	Normal Operation
Daily Status	RESET TO SAVE (LED is NOT lit)	This message is displayed when the printer cannot be reset automatically to exit from the menu. This is because there are data, DLLS, and macros having temporary attributes when the printer is changed from set mode to another mode.	Normal Operation
Daily Status	SWITCH-ING( LED is NOT lit)	The emulation is being switched.  This is done by changing the emulation through the menu or through a software command on-line.	Normal Operation

---

## Front Panel Messages: Paper, Cover Open, Buffer Overflow

### Front Panel Messages: Paper, Cover Open, Buffer Overflow

Category	LCD Message	Problem	Solution
Paper Messages	TRAYn #REQUEST (LED is NOT lit)	The paper in tray n is NOT the size specified.	Replace the paper in tray n with the size of paper specified by # request  TRAYnn = 1, 2, or feeder  #REQUEST# = LETTR, EXECUTIV, LEGAL 14, LEGAL 13, A4Size, A5 SIZE, A6 SIZE, B5 SIZE, FREE SIZE
Paper Messages	MANUAL #REQUEST (LED is NOT lit)	Request for manual feed.	Manually feed the size of paper specified by # REQUEST#REQUEST# = LETTER, EXECUTIV, LEGAL 14, LEGAL 13, A4Size, A5 SIZE, A6 SIZE, B5Size, FREE SIZE, COM-10, MONARCH, DL ENV, C5ENV
Paper Messages	CLEANING MANUAL# (LED is NOT lit)	Request for cleaning manual feed.	Manually feed the size of paper specified by MANUAL## = LETTER, A4 SIZE
Paper Messages	TRAYn PAPEROUT (LED is NOT lit)	No paper in TRAY n or no paper cassette installed in position n  TRAYnn = 1, 2, or feeder	Place paper into the tray or Install the paper cassette.
Paper Messages	COVER T2 OPEN (LED is NOT lit)	TRAY2 cover is open.Cover must be closed for operation to continue.	Close the cover

Paper Messages	PAGE BUFF OVERFLOW (LED is NOT lit)	The page buffer overflowed.	<ol style="list-style-type: none"> <li>1. Press the operator panel RECOVERY key to release the error display.</li> <li>2. Increase RAM size.</li> <li>3. Reduce the amount of print data.</li> </ol>
Paper Messages	MACRO OVERFLOW (LED is NOT lit)	The macro buffer overflowed.	<ol style="list-style-type: none"> <li>1. Press the operator panel RECOVERY key to release the error display.</li> <li>2. Increase RAM size.</li> <li>3. Reduce the number of macros.</li> </ol>
Paper Messages	DLL BUFF OVERFLOW (LED is NOT lit)	The DLL buffer overflowed.	<ol style="list-style-type: none"> <li>1. Press the operator panel RECOVERY key to release the error display.</li> <li>2. Increase RAM size.</li> <li>3. Reduce the number of DLLs.</li> </ol>

---

## Front Panel Messages: Buffer Overflow, Interface, Paper Size

---

### Front Panel Messages: Buffer Overflow, Interface, Paper Size

Category	LCD Message	Problem	Solution
Buffer Overflow	REC BUFF OVERFLOW (LED is NOT lit)	The receive buffer overflowed.	<ol style="list-style-type: none"> <li>1. Press the operator panel RECOVERY key to release the error display.</li> <li>2. Change the setting of the host side so that it can detect the busy status of the printer.</li> <li>3. Resend the data from the host side to the printer.</li> </ol>
Buffer Overflow	PRINT OVERRUN (LED is NOT lit)	The print data is too complicated to be printed.	<ol style="list-style-type: none"> <li>1. Press the operator panel RECOVERY key to release the error display.</li> <li>2. Simplify page data formatting.</li> <li>3. Increase RAM size.</li> </ol>
Interface Errors	HOST I/F ERROR (LED is NOT lit)	An error occurred in the serial interface. A framing error or an overrun error is detected.	<ol style="list-style-type: none"> <li>1. Press the operator panel RECOVERY key to release the display.</li> <li>2. Check the protocol of the host and printer.</li> <li>3. Replace the main controller board.</li> </ol>
Paper Size Error	TRAYn SIZE ERRn (LED is NOT lit)	<p>Wrong size paper was fed from Tray n.</p> <p>ERRn = Error Cause1 = Too wide / too narrow</p> <p>2 = Too long 3 = Too short</p>	<ol style="list-style-type: none"> <li>1. Check paper in tray.</li> <li>2. Check to see if more than one sheet was fed.</li> <li>3. Open, then close the cover.</li> <li>4. Printing will continue.</li> </ol>

---

## Front Panel Messages: Jam, Cover Open, EEPROM, ROM, Card

### Front Panel Messages: Jam, Cover Open, EEPROM, ROM, Card

Category	LCD Message	Problem	Solution
Jam Error	TRAYn Input JAM (LED is NOT lit)	A jam occur during paper feeding from Tray n.	1. Verify that paper is in the cassette, open and then close the cover.  If the error occurs frequently refer to RAP 02 (📄)
Jam Error	TRAYn Feed JAMn (LED is NOT lit)	After feeding paper from Tray n, a jam occurred. JAMn = Location of jam 1= IN-WRITE time2 2= WRITE-OUT time3 3= IN-WRITE TIME (at ejection)	1. Open the cover and remove the paper, then close the cover.  2. If the error occurs frequently, refer to RAP 03 (📄)
Jam Error	PAPER Exit JAMn (LED is NOT lit)	A jam occurred during paper ejecting. JAMn = jam cause 1 = Paper too long 2 = Paper too short	1. Open the cover and remove the paper 2. Close the cover. 3. If the error occurs frequently refer to RAP 04 (📄)
EEPROM Error	ENGINE RESET'NG (LED is NOT lit)	A model information error or revision error was found.	Engine EEPROM is being initialized.
ROM Error	EEPROM RESET'NG (LED is NOT lit)	A Program ROM revision check error occurred.	MENU is being reset to factory defaults.
Cover Open	COVER OPEN (LED is NOT lit)	The upper cover wasopened.	1. Close the cover to release the error display.  2. Replace the main controller board
Card Error	CARD FORMAT (LED is NOT lit)	Card Check found an error.	1. Remove the card. 2. Power OFF the printer. 3. Power ON the printer.
Card Error	CARD ERROR	During power-ON, the card was inserted or removed.	Power OFF, then ON to recover from the error.

## Front Panel Messages: Controller Errors

### Front Panel Messages: Controller Errors

Category	LCD Message	Problem	Solution
Controller Error	ERROR nn (LED is NOT lit)	An error occurred with controller board.	<ol style="list-style-type: none"> <li>1. Power OFF, then ON to recover from the error.</li> <li>2. If the problem remains, use the following solutions.</li> </ol>
Controller Error	ERROR 10	An error was detected by the program ROM check.	Replace the main controller board.
Controller Error	ERROR 20	An error was detected by the font ROM check.	Replace the main controller board.
Controller Error	ERROR 30	An error was detected by the resident RAM check.	Replace the main controller board.
Controller Error	ERROR 40	An error was detected by the EEPROM check	Replace the EEPROM. Replace the main controller board.
Controller Error	ERROR 50	An Font Card error was detected.	<ol style="list-style-type: none"> <li>1. Verify that the Font Card is properly connected</li> <li>2. Replace the Font Card, if the problem continues replace the main controller board</li> </ol>
Controller Error	ERROR 60	An optional RAM board error was detected.	<ol style="list-style-type: none"> <li>1. Verify that the optional RAM board is properly connected.</li> <li>2. Replace the optional RAM board if the problem continues, replace the main controller board.</li> </ol>
Controller Error	ERROR 70	A fault occurred with the fan motor.	<ol style="list-style-type: none"> <li>1. Verify that the fan motor is properly connected then replace the fan motor.</li> <li>2. Replace the main controller board.</li> </ol>

Controller Error	ERROR 71	A fault occurred with the fusing unit.	1. Replace the fusing unit. 2. Replace the main controller board.
Controller Error	ERROR 72	A fault occurred with the thermistor (Open Check Error)	1. Replace the fusing unit. 2. Replace the main controller board.
Controller Error	ERROR 73	A fault occurred with the thermistor. (Short Check Error)	1. Replace the fusing unit. 2. Replace the main controller board,
Controller Error	ERROR 80	Interface time-out occurred between the main controller board and the operator panel.	If this error occurs frequently, replace the following. 1. Flexible cable. 2. Operator panel 3. Main controller board
Controller Error	ERROR 81	Interface time-out occurred between the main controller board and the optional tray.	1. Replace the main controller board 2. Replace the optional envelope tray.
Controller Error	ERROR 90	A watchdog timer time-out occurred.	If this error occurs frequently, replace the main controller board.
Controller Error	ERROR F0	Firmware Program Error	1. Replace the PROM. 2. Replace the main controller board.
Controller Error	ERROR F1	Firmware Program Error	"" "" "" same as F0 error
Controller Error	ERROR F2	Firmware Program Error	"" "" "" same as F0 error
Controller Error	ERROR F3	Firmware Program Error	"" "" "" same as F0 error
Controller Error	ERROR F4	Firmware Program Error	"" "" "" same as F0 error
Controller Error	ERROR F5	Firmware Program Error	"" "" "" same as F0 error



Controller Error	ERROR F6	Firmware Program Error	"" "" "" same as F0 error
Controller Error	ERROR F7	Firmware Program Error	"" "" "" same as F0 error

Category	LCD Message	Problem	Solution
Controller Error	ERROR On aaaaaaaa  (LED is NOT lit)	An error occurred in the controller.  n = Exception Code  aaaaaaaa = Error Address	1. Power OFF the printer.  2. Power ON the printer.  3. If the problem remains, replace the main controller board.
		Exception Codes	Error Contents
		1	Reserved
		2	Reserved
		3	Reserved
		4	Address Error Exception (Load Command, Command Fetch)
		5	Address Error Exception (Store Command)
		6	Bus Error Exception (Command Fetch)
		7	Bus Error Exception (Load Command, Store Command)
		8	System Call Exception
		9	Break Point Exception
		A	Reserved Instruction Exception
		B	Coprocessor Unusable Exception

		C	Arithmetic Overflow Exception
		D	Reserved
		E	Reserved
		F	Reserved

---

## Front Panel Messages: Additional OL410E-PS

---

### Front Panel Messages: OL410e/PS

The LCD panel messages displayed by the OL410e/PS LED Page Printer are identical to those displayed by the OL410e, with the following exceptions.

LCD MESSAGE	ON-LINE LED STATUS	DEFINITION	RECOMMENDED ACTION
PROCS'NG	OFF	The printer is processing data in PostScript Mode	Normal Operation
WAITING	OFF	The printer is in the middle of a job and waiting for data to be processed.	Normal Operation
RESET TO FLUSH	N/A	This message is displayed if: <ol style="list-style-type: none"><li>JOB RESET (in the printer is set to ON</li><li>The printer is processing a job</li><li>The ON-LINE Key is pressed</li></ol>	<ol style="list-style-type: none"><li>Press ON-LINE The printer returns on-line and continues to process the data.</li><li>Press RECOVER/Reset</li></ol> The job is cancelled.
FLUSHING	OFF	This message is displayed during the cancelling of a job.	Normal Operation
ERROR PSAdobePS	N/A	This message appears when the PostScript Interpreter detects an error during job processing. The remainder of the job will be ignored.	Check the printer settings of the Host Computer.  Check the print job for un-supported operations.

---

## 4.7 Repair Analysis Procedures (RAPS) - Index

---

### 4.7 REPAIR ANALYSIS PROCEDURES (RAPs)

When using the Repair Analysis Procedures, follow these steps.

- Go to the RAP Index.
- Find the RAP which is associated with the printer's problem.
- Go to the appropriate RAP.
- All RAPs begin with a START statement, followed by questions or another type of statement.

Rap #	Description
1	Printer Does Not Initialize. (📄)
2	Paper Input Jam. (📄)
3	Paper Feed Jam. (📄)
4	Paper Exit Jam. (📄)
5	Paper Size Error. (📄)
6	Fuser Unit Error (ERROR 71). (📄)
7	Fan (ERROR 70). (📄)
8	Light or Blurred Output. (📄)
9	Dark Background. (📄)
10	Blank Output. (📄)
11	Vertical Black Streaks. (📄)
12	Evenly Spaced, Repeating Marks. (📄)
13	Missing Print. (📄)
14	Poor Fusing. (📄)
15	Vertical White Streaks. (📄)

---

# RAP 01: Printer Does Not Initialize

## RAP 01: Printer Does Not Initialize

### START

Power OFF the printer, then power the printer ON.

Are all 8s displayed on the operator panel?

NO Is the AC cable properly connected?

YES Go to STEP-1.

NO Correctly connect the cable.

YES Does INITIALIZING appear on the LCD display?

NO Replace the main control board.

YES Is the ON LINE / "emulation" message displayed on the LCD display?

YES End of procedure.

NO Replace the main controller board.

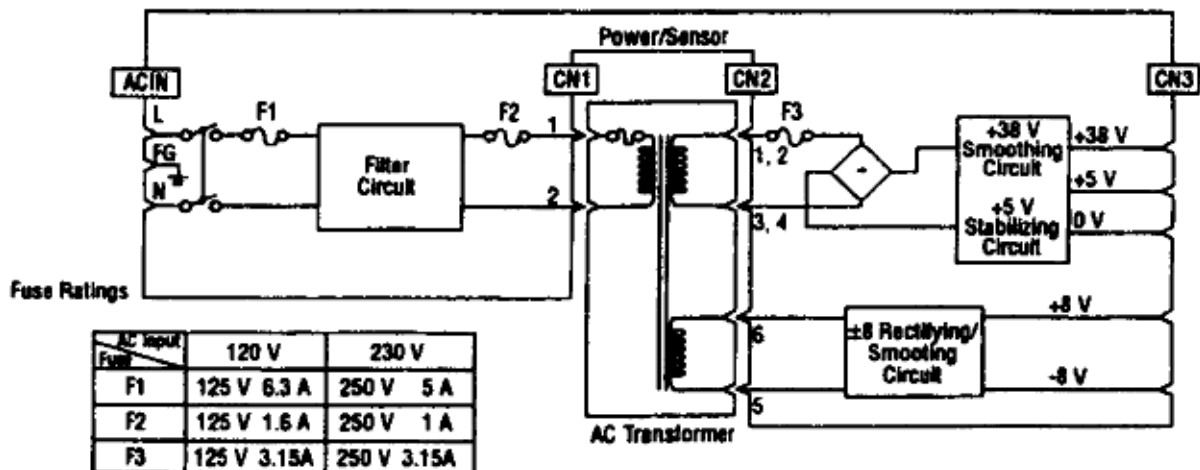

### STEP-1

Is +5vdc present between pins 26 and 14 (GND) of CN7 on the main controller board?

NO Disconnect connector CN7 on the main controller board from connector CN3 of the power supply board, then reconnect these connectors.

YES Is +8vdc present between pins 30 and 31 (GND) on connector CN7 on the main controller board?

YES Replace the main controller board.

NO Verify that the main controller board and the power supply board are properly connected.

Are the power supply board and the main controller board properly connected?

NO Properly connect them.

YES Measure the following voltages at connector CN2 on the power supply board.

Voltage between pin 1 and Frame Ground should be approximately 28vac.

Voltage between pin 5 and Frame Ground should be approximately 10vac.

Are the voltages normal?

NO Go to STEP-2.

YES Is fuse F3 on the power supply board open?

YES Replace fuse F3.

NO Replace the power supply board.

## **STEP-2**

Is the AC input voltage present between pins 1 and 2 of connector CN1 on the power supply board?

YES Replace the AC transformer.

NO Is fuse F1 or F2 on the power supply board open?

YES Replace Fuse F1 or F2.

NO Replace the power supply board.

Has the problem been resolved?

YES End of procedure.

NO Contact Technical Support.

## \*RAP 02: Paper Input Jam

---

### RAP 02: Paper Input Jam

#### START

The jam alarm occurs as soon as the printer is powered ON.

Is paper at the inlet sensor?

YES Remove the paper.

NO Insure that the inlet sensor plate is properly operating (moves freely when touched).

Has the problem been resolved?

YES End of procedure.

NO Replace the inlet sensor plate.

Has the problem been resolved?

YES End of procedure.

NO Replace the power supply board.

The jam alarm occurs after paper feeding.

Is the paper fed onto the inlet sensor plate?

YES Check the operation of the inlet sensor plate. It should move freely when touched.

NO Perform the following procedures (in the order listed).

- Refer to Section 4.4.05 (📄) of this Service Handbook.
- Replace the hopping roller assembly.
- Replace the paper cassette tray.

Does the inlet sensor plate move freely when touched?

YES Clean the inlet sensor on the power supply board.

NO Replace the inlet sensor plate.

Has the problem been resolved?

YES End of procedure.

NO Replace the paper cassette tray.

Is the hopping roller rotating?

YES Properly install the paper cassette tray.

NO Is the registration motor rotating properly?

YES Replace the one-way clutch of the hopping roller assembly.

NO Ensure that connector CN3 on the main controller board is properly connected.

Is the coil resistance of the registration motor 32 ohms? Refer to Section 4.9 (.

YES Replace the main controller board.

NO Replace the registration motor.

---



## \*RAP 03: Paper Feed Jam

---

### RAP 03: Paper Feed Jam

#### START

Does a paper feed jam occur as soon as the printer is powered ON?

- YES Is the paper on the paper sensor plate?
  - YES Remove the paper.
  - NO Is the paper sensor plate operating normally (moves freely when touched)?
    - NO Replace the paper sensor plate.
    - YES Replace the power supply board.
  - NO Has the paper reached the paper sensor plate?
    - NO Is the registration roller rotating?
      - NO Replace the one-way clutch.
      - YES Refer to Section 4.4.06 of this Service Handbook.
    - Is the image drum cartridge installed properly ?
      - NO Properly install the image drum cartridge.
      - YES Verify that the manual feed paper guide is properly closed.
  - YES Has the paper reached the outlet sensor plate?
    - YES Is the outlet sensor plate operating normally?
      - NO Replace the outlet sensor plate.
      - YES Clean the outlet sensor on the power supply board or replace the power supply board.
    - NO Go to Step A

#### Step A

- NO Is the drum rotating?
  - NO Is connector CN2 on the main controller board properly connected?
    - NO Connect connector CN2 properly.
    - YES Is the coil resistance of the drum motor normal, 32 ohms?

NO Replace the drum motor.

YES Replace the main controller board.

YES Is the transfer roller rotating properly?

NO Check the transfer roller gear.

CAUTION: Do not touch the transfer roller! Touching the transfer roller may cause incomplete toner transfer, resulting in faded output.

YES Are the fusing unit rollers rotating?

NO Replace the transfer roller gear.

YES Is the image drum cartridge installed properly?

NO Properly install the image drum cartridge.

YES Clean the inlet sensor on the power supply board.

## **\*RAP 04: Paper Exit Jam**

---

### **RAP 04: Paper Exit Jam**

#### **START**

Does the paper exit jam occur as soon as the printer is powered ON?

YES Is the paper on the outlet sensor plate?

YES Remove the paper.

NO Refer to Section 4.4.06 of this Service Handbook.

Does the outlet sensor plate move freely when touched?

NO Replace the outlet sensor plate.

YES Replace the power supply board.

NO Is the face-up stacker drawn out or pushed into the printer completely?

NO Draw the face-up stacker out of the printer completely, then push it into the printer completely.

YES Replace the outlet roller assembly.

---

## RAP 05: Paper Size Error

---

### RAP 05: Paper Size Error

#### START

Is the paper used designed for use in laser printers?

- NO Use paper designed for use in laser printers.
- YES Do inlet sensor plates 1 and 2 operate properly (move freely when touched)?
  - NO Clean the inlet sensor on the power supply board or replace the inlet sensor plate.
  - YES Does the outlet sensor plate move freely when touched?
    - NO Clean the outlet sensor on the power supply board or replace the outlet sensor plate.
    - YES Replace the power supply board.

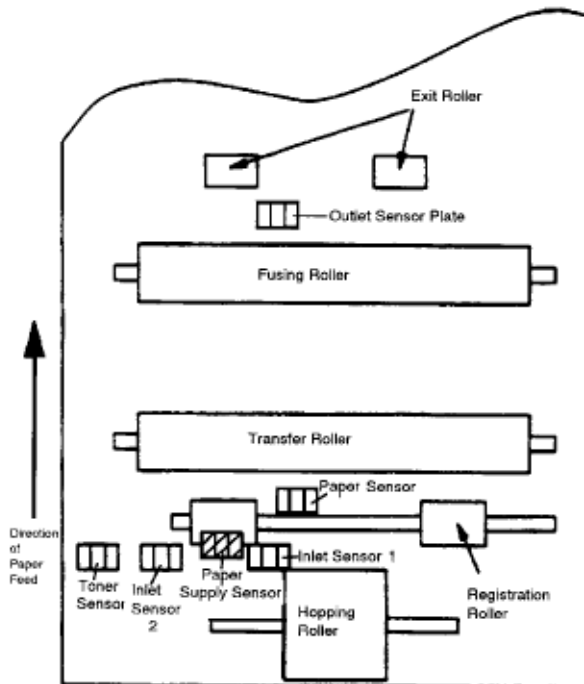

## RAP 06: Fusing Unit Error (Error 71)

---

### RAP 06: Fusing Unit Error (ERROR 71)

#### START

Power OFF the printer, then power ON the printer.

*Does a fusing unit error occur immediately?*

YES Is the resistance between the thermistor contacts correct?

*It should read 220k ohms at room temperature.*

YES Replace the fusing unit.

NO Does the thermistor contact touch the contact assembly properly when the fusing unit is mounted in the printer?

NO Adjust the contact.

YES Replace the main controller board.

*If the problem is not resolved, replace the power supply board.*

NO Does the fusing unit error occur about 60 seconds after powering ON the printer?

NO Check the thermistor for poor contact.

*If the problem is not resolved, replace the main controller board.*

YES Power OFF the printer. Then, power ON the printer.

*Is the lamp of the fusing unit ON? When the lamp is ON, light can be seen at the fuser.*

YES Replace the fusing unit.

*If the problem is not resolved, replace the main controller board.*

NO Is the fuser or thermistor open?

*Measure the resistance between the fuser contacts. Normal resistance is about zero Ohms.*

YES Replace the fusing unit.

NO Is the AC voltage for the fuser present at the contact assembly?

NO Replace the main controller board.

*If the problem is not resolved, replace the power supply board.*

YES Check the electrical contacts of the fusing unit.

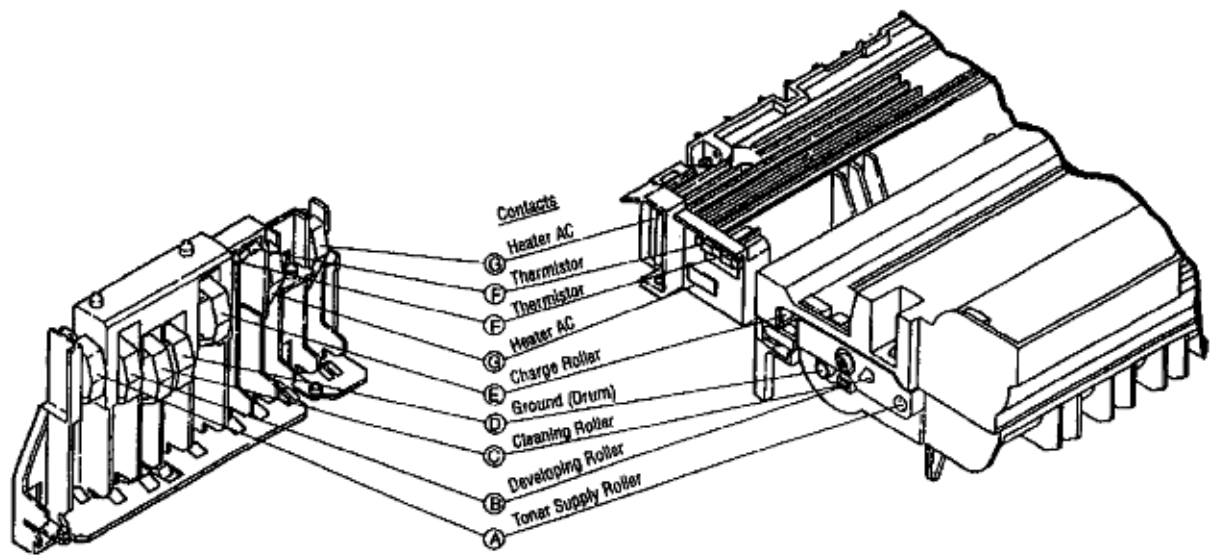

## RAP 07: Fan Error (Error 70)

---

### RAP 07: Fan Error (ERROR 70)

#### START

*Is the fan rotating?*

YES    Replace the main controller board.

NO     Is connector CN1 on the main controller board properly connected?

NO     Properly connect connector CN1.

YES    Replace the fan.

*If the problem is not resolved, replace the main controller board.*

---

## \*RAP 08: Light Or Blurred Output

---

### RAP 08: Light or Blurred Output

#### START

Refer to Section 4.5 of this Service Handbook before proceeding.

*Is the TONER LOW message displayed?*

YES Add toner.

NO Is the paper used designed for use in laser printers?

NO Use paper designed for use in laser printers.

YES Is the lens surface of the LED head dirty?

YES Clean the lens.

NO Is the LED head installed properly?

*Check connector CN4 of the main controller board      proper connection.*

NO Properly install the LED head.

YES Is the contact plate of the transfer roller properly touching the power supply board?

NO Adjust the transfer roller contact plate to properly touch the power supply board.

YES Are the contacts of the developing roller and the contact of the transfer roller properly touching the contact assembly?

NO Adjust the contacts of the developing roller and transfer roller to touch the contact assembly.

YES Replace the transfer roller.

*Has the problem been resolved?*

YES End of procedure.

NO Replace the image drum cartridge.

*Has the problem been resolved?*

YES End of procedure.

NO Replace the main controller board.

*If the problem is not resolved, replace the power supply board.*

---



## \*RAP 09: Dark Background

---

### RAP 09: Dark Background

#### START

Refer to Section 4.5 of this Service Handbook before proceeding.

*Has the image drum been exposed to external light?*

YES Place the image drum cartridge into the printer and wait about 30 minutes.

NO Is the heat roller of the fusing unit dirty?

YES Clean the roller.

NO Is the contact of the cleaning roller (of the image drum) properly touching the contact assembly?

NO Adjust the contact of the cleaning roller to properly touch the contact assembly.

YES Replace the image drum cartridge.

*Has the problem been resolved?*

YES End of procedure.

NO Replace the main controller board.

*If the problem is not resolved, replace the power supply board.*

---

## **\*RAP 10: Blank Output**

---

### **RAP 10: Blank Output**

#### **START**

Refer to Section 4.5 of this Service Handbook before proceeding.

*Is the LED head connected? Check connector CN4 on the main controller board.*

NO     Connect the LED head.

YES    Is the image drum cartridge touching the ground contact?

NO     Connect the image drum cartridge to properly touch the ground contact.

YES    Replace the LED head.

*Has the problem been resolved?*

YES    End of procedure.

NO     Replace the main controller board.

*If the problem is not resolved, replace the power supply board.*

---

## **\*RAP 11: Vertical Black Streaks**

---

### **RAP 11: Vertical Black Streaks**

#### **START**

Refer to Section 4.5 of this Service Handbook before proceeding.

*Is the TONER LOW message displayed?*

YES Add toner.

NO Replace the image drum cartridge.

*Has the problem been resolved?*

YES End of procedure.

NO Replace the LED head.

*Has the problem been resolved?*

YES End of procedure.

NO Replace the main controller board.

*If the problem is not resolved, replace the power supply board.*

---

## **\*RAP 12: Evenly Spaced, Repeating Marks**

---

### **RAP 12: Evenly Spaced, Repeating Marks**

#### **START**

Refer to Section 4.5 of this Service Handbook before proceeding.

- 1) Measure the distance between marks.
- 2) Find the measurement in the table below.
- 3) Perform the corrective action.

<b>Distance Between Marks</b>	<b>Corrective Action</b>
1.24 inches	Replace the image drum cartridge.
1.56 inches	Replace the image drum cartridge.
1.66 inches	Clean or replace the image drum cartridge.
2.01 inches	Replace the transfer roller.
2.23 inches	Replace the pressure roller.
2.27 inches	Replace the image drum cartridge.
2.47 inches	Replace the fusing unit assembly.
3.71 inches	Replace the image drum cartridge.

---

## \*RAP 13: Missing Print

---

### RAP 13: Missing Print

START

Refer to Section 4.5 of this Service Handbook before proceeding.

*Is the contact plate of the transfer roller touching the power supply board?*

NO Adjust the transfer roller contact plate to properly touch the power supply board.

YES Replace the transfer roller.

*Has the problem been resolved?*

YES End of procedure.

NO Are the contacts of the transfer roller, developing roller, image drum, and charging roller properly touching the contact assembly?

NO Adjust the contacts to touch the contact assembly.

YES Replace the image drum cartridge.

*Has the problem been resolved?*

YES End of procedure.

NO Is the LED head installed properly? Check connector CN4 on the main controller board board.

NO Properly install the LED head.

YES Replace the LED head.

*Has the problem been resolved?*

YES End of procedure.

NO Replace the main controller board.

*If the problem is not resolved, replace the power supply board.*

---

## **\*RAP 14: Poor Fusing**

---

### **RAP 14: Poor Fusing**

#### **START**

*Is the paper used designed for use in laser printers?*

NO Use paper designed for use in laser printers.

YES Does the pressure roller spring compress and expand normally?

NO Replace the spring.

YES Is the contact of the fusing unit assembly properly touching the contact assembly?

NO Adjust the fusing unit assembly to properly touch the contact assembly.

YES Replace the fusing unit assembly.

*Has the problem been resolved?*

YES End of procedure.

NO Replace the main controller board.

---

## \*RAP 15: Vertical White Streaks

---

### RAP 15: Vertical White Streaks

#### START

Refer to Section 4.5 of this Service Handbook before proceeding.

*Is the LED lens dirty?*

YES Clean the LED lens.

NO Is the transfer roller plate properly touching the power supply board?

NO Adjust the transfer roller to properly touch the power supply board.

YES Replace the transfer roller.

*Has the problem been resolved?*

YES End of procedure.

NO Is the LED head properly installed? Check connector CN4 on the main controller board.

NO Install the LED head properly.

YES Replace the LED head.

*Has the problem been resolved?*

YES End of procedure.

NO Replace the image drum cartridge.

*Has the problem been resolved?*

YES End of procedure.

NO Replace the main controller board.

---

## 4.8 Printer Tests - Font Sample Test

---

### 4.8 PRINTER TESTS - Font Sample Test

The Font Test Sample prints samples of the various fonts that can be printed by the printer.

To perform the Font Sample Test, follow this procedure.

- Power ON the printer and wait for it to go ON-LINE.
- Press ON-LINE to place the printer OFF-LINE.
- Press PRINT MENU / Print Fonts for 2 seconds.
- The message PRINT FONTS will be displayed on the LCD Display and, after a few moments, the Font Samples will print.
- When printing is completed, the printer will be OFF-LINE.
- Press ON-LINE to place the printer ON-LINE.

**NOTE:**

The Font Sample does not include samples of landscape orientation.

All resident scalable fonts can be printed in landscape and portrait orientation.

---



# Font Sample Test: OL400E

Font Sample test: OL400e

## OL400e LED Page Printer

### HP® LaserJet® IIP Emulation

Font No.	Font ID	Ori ent	Font Name	(Style)(Weight)	Pitch (CPI)	Point Size	Num.of Symbol	Print Sample
----------	---------	---------	-----------	-----------------	-------------	------------	---------------	--------------

### HP LaserJet IIP Resident Bitmapped Fonts

1000		P	Courier		10.00	12.0	40	ABCDEFghijkl01234 #
1001		P	Courier	Bold	10.00	12.0	40	<b>ABCDEFghijkl01234 #</b>
1002		P	Courier	Italic	10.00	12.0	40	<i>ABCDEFghijkl01234 #</i>
1003		P	Courier		12.00	10.0	40	ABCDEFghijkl01234 # \$ % &
1004		P	Courier	Bold	12.00	10.0	40	<b>ABCDEFghijkl01234 # \$ % &amp;</b>
1005		P	Courier	Italic	12.00	10.0	40	<i>ABCDEFghijkl01234 # \$ % &amp;</i>
1006		P	LN Printer		16.67	8.5	40	ABCDEFghijkl01234 # \$ % & @ [ \ ] ^ _ (

### HP B/F Cartridge Compatible Resident Bitmapped Fonts

1007		P	Swiss	Bold	prop(B)	14.4	1	<b>ABCDEFghijkl01234</b>
1008		P	Swiss	Bold	prop(F)	14.4	40	<b>ABCDEFghijkl01234</b>
1009		P	Dutch		prop(B)	10.0	1	ABCDEFghijkl01234 # \$ % &
1010		P	Dutch	Bold	prop(B)	10.0	1	<b>ABCDEFghijkl01234 # \$ % &amp;</b>
1011		P	Dutch	Italic	prop(B)	10.0	1	<i>ABCDEFghijkl01234 # \$ % &amp;</i>
1012		P	Dutch		comp(B)	10.0	1	ABCDEFghijkl01234 # \$ % & @
1013		P	Dutch	Bold	comp(B)	10.0	1	<b>ABCDEFghijkl01234 # \$ % &amp; @</b>
1014		P	Dutch	Italic	comp(B)	10.0	1	<i>ABCDEFghijkl01234 # \$ % &amp; @</i>
1015		P	Dutch		prop(F)	10.0	40	ABCDEFghijkl01234 # \$ % &
1016		P	Dutch	Bold	prop(F)	10.0	40	<b>ABCDEFghijkl01234 # \$ % &amp;</b>
1017		P	Dutch	Italic	prop(F)	10.0	40	<i>ABCDEFghijkl01234 # \$ % &amp;</i>
1018		P	Dutch		prop(B)	8.0	1	ABCDEFghijkl01234 # \$ % & @ [ \ ] ^ _
1019		P	Dutch		comp(B)	8.0	1	ABCDEFghijkl01234 # \$ % & @ [ \ ] ^ _
1020		P	Dutch		prop(F)	8.0	40	ABCDEFghijkl01234 # \$ % & @ [ \ ] ^ _

### Card Fonts

### Permanent Soft Fonts

HP and LaserJet are registered trademarks of Hewlett-Packard Company. Swiss and Dutch are trademarks of Bitstream, Inc.

# Font Sample Test: OL410E

---

Font Sample test: OL410e

# OL410e LED PAGE PRINTER

## HP® LaserJet® III Emulation

Font No.	Font ID	Orient	Font Name	(Style) (Weight)	Pitch (CPI)	Point Size	Num. of Symbol	Print Sample
<b>HP LJ III Resident Fonts</b>								
1000		P	Courier		fixed	scale	55(0)	ABCDEFghijkl01234 # \$ % & @ Å Ì
1001		P	Courier	Bold	fixed	scale	55(0)	ABCDEFghijkl01234 # \$ % & @ Å Ì
1002		P	Courier	Italic	fixed	scale	55(0)	ABCDEFghijkl01234 # \$ % & @ Å Ì
1003		P	Courier	Italic Bold	fixed	scale	55(0)	ABCDEFghijkl01234 # \$ % & @ Å Ì
1004		P	CG Times		prop	scale	60(0)	ABCDEFghijkl01234 # \$ % & @ À Ê Ì Ò
1005		P	CG Times	Bold	prop	scale	60(0)	ABCDEFghijkl01234 # \$ % & @ À Ê Ì
1006		P	CG Times	Italic	prop	scale	60(0)	ABCDEFghijkl01234 # \$ % & @ À Ê Ì Ò
1007		P	CG Times	Italic Bold	prop	scale	60(0)	ABCDEFghijkl01234 # \$ % & @ À Ê Ì
1008		P	Univers		prop	scale	60(0)	ABCDEFghijkl01234 # \$ % & @ À Ê
1009		P	Univers	Bold	prop	scale	60(0)	ABCDEFghijkl01234 # \$ % & @ À Ê
1010		P	Univers	Italic	prop	scale	60(0)	ABCDEFghijkl01234 # \$ % & @ À Ê
1011		P	Univers	Italic Bold	prop	scale	60(0)	ABCDEFghijkl01234 # \$ % & @ À Ê
1012		P	LN Printer		16.66	8.5	40	ABCDEFghijkl01234 # \$ % & @ À Ê Ì Ò ù à ä ý

1013 P USPS ZIP

prop 64.8 4



### Card Fonts

### Permanent Soft Fonts

HP and LaserJet are registered trademarks of Hewlett-Packard Company.  
Univers is a registered trademark of Linotype AG and/or its subsidiaries.

# Font Sample Test: OL410E-PS

Font Sample test: OL410e-PS

**OL410e/PS**

## PostScript Font Availability List

AdobeSansXMM	The quick brown fox jumped over the lazy dog.
AdobeSerifMM	The quick brown fox jumped over the lazy dog.
AvantGarde-Book	The quick brown fox jumped over the lazy dog.
AvantGarde-BookOblique	<i>The quick brown fox jumped over the lazy dog.</i>
AvantGarde-Demi	<b>The quick brown fox jumped over the lazy dog.</b>
AvantGarde-DemiOblique	<b><i>The quick brown fox jumped over the lazy dog.</i></b>
Bookman-Demi	<b>The quick brown fox jumped over the lazy dog.</b>
Bookman-Demibold	<b><i>The quick brown fox jumped over the lazy dog.</i></b>
Bookman-Light	The quick brown fox jumped over the lazy dog.
Bookman-Lightitalic	<i>The quick brown fox jumped over the lazy dog.</i>
Courier	The quick brown fox jumped over the lazy dog.
Courier-Bold	<b>The quick brown fox jumped over the lazy dog.</b>
Courier-BoldOblique	<b><i>The quick brown fox jumped over the lazy dog.</i></b>
Courier-Oblique	<i>The quick brown fox jumped over the lazy dog.</i>
Helvetica	The quick brown fox jumped over the lazy dog.
Helvetica-Bold	<b>The quick brown fox jumped over the lazy dog.</b>
Helvetica-BoldOblique	<b><i>The quick brown fox jumped over the lazy dog.</i></b>
Helvetica-Narrow	The quick brown fox jumped over the lazy dog.
Helvetica-Narrow-Bold	<b>The quick brown fox jumped over the lazy dog.</b>
Helvetica-Narrow-BoldOblique	<b><i>The quick brown fox jumped over the lazy dog.</i></b>
Helvetica-Narrow-Oblique	<i>The quick brown fox jumped over the lazy dog.</i>
Helvetica-Oblique	<i>The quick brown fox jumped over the lazy dog.</i>
NewCenturySchlbk-Bold	<b>The quick brown fox jumped over the lazy dog.</b>
NewCenturySchlbk-Bolditalic	<b><i>The quick brown fox jumped over the lazy dog.</i></b>
NewCenturySchlbk-Italic	<i>The quick brown fox jumped over the lazy dog.</i>
NewCenturySchlbk-Roman	The quick brown fox jumped over the lazy dog.
Palatino-Bold	<b>The quick brown fox jumped over the lazy dog.</b>
Palatino-Bolditalic	<b><i>The quick brown fox jumped over the lazy dog.</i></b>
Palatino-Italic	<i>The quick brown fox jumped over the lazy dog.</i>
Palatino-Roman	The quick brown fox jumped over the lazy dog.
Symbol	Τηρ θυαγκ βρωπ σσξ φυμρεδ σσηρ τηρ λαξψ δογ.
Times-Bold	<b>The quick brown fox jumped over the lazy dog.</b>
Times-Bolditalic	<b><i>The quick brown fox jumped over the lazy dog.</i></b>
Times-Italic	<i>The quick brown fox jumped over the lazy dog.</i>
Times-Roman	The quick brown fox jumped over the lazy dog.
ZapfChancery-Mediumitalic	<i>The quick brown fox jumped over the lazy dog.</i>
ZapfDingbats	*** □♦*** ◊◢◣◤ ◊◥◦◧◨ ◊◩◪ ◊◭◮ ◊◯◰◱ ◊◲◳◴ ◊◵◶ ◊◷◸◹◺ ◊◻◼◽◾◿

Font Sample Test: OL410e/PS

# OL410e/PS



**Adobe PostScript**

Adobe PostScript™ Level 2 and  
HP® LaserJet® III emulations.



Powerful RISC microprocessor  
for ultra fast performance.

**600  
DPI CLASS**

600 DPI Class output  
for superior print quality.



Parallel, serial and AppleTalk™  
interfaces for both PC and MAC users.



Reliable LED print head  
for assured quality and long life.

Adobe, PostScript and the PostScript Logo are registered trademarks of Adobe Systems Incorporated, which may be registered in certain jurisdictions.  
AppleTalk is a trademark of Apple Computer Inc.  
HP and LaserJet are Registered trademarks of Hewlett-Packard Company



## 4.8.03 Serial Interface Loopback Test

---

### 4.8.03 Serial Interface Loopback Test

The Serial Interface Loopback Test verifies the proper operation of the serial port and its associated circuitry.

To perform the Serial Interface Loopback Test do the following.

- You need a 9 to 25 pin adapter, if you do not have a 9 pin Loopback Test Connector.
- Place a DB-25P or 9 pin Loopback Test Connector on the serial port (The configuration is shown below).
- Press and hold RECOVERY while powering ON the printer to select the System Maintenance Mode.
- Toggle through the selections by pressing MENU1/MENU2 until you get to Loop test.
- Press ENTER to start the Loopback Test.
- When an error occurs during this test, a corresponding error message will be displayed.
- Press ON-LINE to exit this test

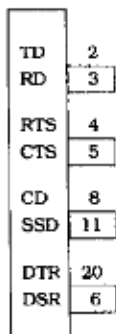

**RS232-C (DB 25P Plug)**

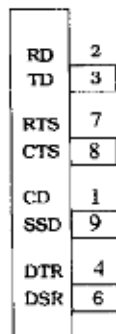

**RS232 (DB 9 P Plug)**

---

## 4.8.04 Menu Print

---

### 4.8.04 Menu Print

The Menu Print Function provides the information listed below to the service technician.

Program ROM Revision Level

Font ROM Revision Level

Amount of Printer Page Memory

Factory Menu Settings

User Selected Menu settings

To print the Menu, follow this procedure.

- Power ON the printer and wait for it to go ON-LINE.
  - Press ON-LINE to place the printer OFF-LINE.
  - Press PRINT MENU / Print Font for 1 second.
  - The message PRINT MENU will appear on the operator panel.
  - The Print Menu Test will print.
  - Once printing is complete, the printer will be OFF-LINE.
  - Press ON-LINE to place the printer ON-LINE.
-



# Sample Menu: OL400E

Sample menu: OL400e

Sample Menu: OL400e

## OL400e LED Page Printer

Program ROM : F/W 01.13 A00 FONT 01.00  
Page Memory : 0.5M Bytes Installed

### Operator Panel Menu Settings

#### Level-1

Category	Item	Factory	User
<b>Common</b>			
PRINTER LANGUAGE	EMULATE	HPIIP	HPIIP
TRAY SELECT	PAPER IN	TRAY	TRAY
PAPER SIZE	TRAY	LETTR	LETTR
	MANUAL	LETTR	LETTR
COPIES	COPIES	1	1
<b>HP® LaserJet® IIP Emulation</b>			
<b>FONTS &amp; SYMBOLS</b>			
	FONT SRC	RESIDENT	RESIDENT
	FONT No.	I000	I000
	SYMBOL	Roman-8	Roman-8
	HP CART	NONE	NONE
<b>PAGE LAYOUT</b>			
	ORIENT	PORTRT	PORTRT
	LINES/PG	60 LNS	60 LNS
	A4 WIDTH	78 COL	78 COL
	BLNKSKIP	OFF	OFF
<b>Common</b>			
HOST I/F	HOST I/F	AUTO IF	AUTO IF

#### Level-2

MEMORY USAGE	REC BUFF	8 KB	8 KB
AUTO OPERATION	AUTOCONT	OFF	ON
	AUTOEJCT	OFF	15 SEC
DARKNESS CONTROL	DARKNESS	0	+2
POWER SAVING	PWR SAVE	ENABLE	DISABLE
PARALLEL I/F	I-PRIME	OFF	ON
RS232C SERIAL	FLOW CTL	DTR HI	DTR HI
	BAUDRATE	9600	9600
	DATABITS	8 BITS	8 BITS
	PARITY	NONE	NONE
	MIN BUSY	200mSEC	200mSEC

HP and LaserJet are registered trademarks of Hewlett-Packard Company.



# Sample Menu: OL410E

Sample menu: OL410e

Sample Menu: OL400e

## OL400e LED Page Printer

Program ROM : F/W 01.13 A00 FONT 01.00  
 Page Memory : 0.5M Bytes Installed

### Operator Panel Menu Settings

#### Level-1

Category	Item	Factory	User
<b>Common</b>			
PRINTER LANGUAGE	EMULATE	HPIIP	HPIIP
TRAY SELECT	PAPER IN	TRAY	TRAY
PAPER SIZE	TRAY	LETTR	LETTR
	MANUAL	LETTR	LETTR
COPIES	COPIES	1	1
<b>HP® LaserJet® IIP Emulation</b>			
<b>FONTS &amp; SYMBOLS</b>			
	FONT SRC	RESIDENT	RESIDENT
	FONT No.	I000	I000
	SYMBOL	Roman-8	Roman-8
	HP CART	NONE	NONE
<b>PAGE LAYOUT</b>			
	ORIENT	PORTRT	PORTRT
	LINES/PG	60 LNS	60 LNS
	A4 WIDTH	78 COL	78 COL
	BLNKSKIP	OFF	OFF
<b>Common</b>			
HOST I/F	HOST I/F	AUTO IF	AUTO IF

#### Level-2

MEMORY USAGE	REC BUFF	8 KB	8 KB
AUTO OPERATION	AUTOCONT	OFF	ON
	AUTOEJCT	OFF	15 SEC
DARKNESS CONTROL	DARKNESS	0	+2
POWER SAVING	PWR SAVE	ENABLE	DISABLE
PARALLEL I/F	I-PRIME	OFF	ON
RS232C SERIAL	FLOW CTL	DTR HI	DTR HI
	BAUDRATE	9600	9600
	DATABITS	8 BITS	8 BITS
	PARITY	NONE	NONE
	MIN BUSY	200mSEC	200mSEC

HP and LaserJet are registered trademarks of Hewlett-Packard Company.



## Sample Menu: OL410E-PS

---

Sample menu: OL410e-PS

Sample Menu: OL410e/PS

# OL410e/PS

## LED Page Printer

<b>Printer Language</b>	Adobe PS
<b>Paper Feed</b>	Tray 1
<b>Auto Tray Switch</b>	Off
<b>Paper Size</b>	
Tray 1	Letter
Tray 2	---
Feeder	---
<b>Media Type</b>	
Tray 1	Medium
Tray 2	---
Feeder	---
<b>RS422 Port</b>	LocalTalk

<b>PostScript Version</b>	2014.105
<b>Program ROM</b>	F/W 47
<b>RAM Size</b>	2097152
<b>Adobe Memory Booster</b>	

<b>Print Mode</b>	OKI600dpi
<b>Smoothing</b>	Dark
<b>Do Jam Recovery</b>	Off
<b>Do Start Page</b>	Off
<b>Allow Job Reset</b>	Off
<b>Manual Timeout</b>	1 Minute
<b>Wait Timeout</b>	40 Seconds
<b>Font Cache</b>	Auto
<b>Error Report</b>	Off
<b>Job Switch</b>	Per Job
<b>Darkness</b>	0
<b>Power Saving</b>	Disabled
<b>RS232C Serial</b>	
Flow Control	DTR HI Polarity
Baud Rate	9600
Data Bits	8
Parity	None
<b>RS422 Serial</b>	
Baud Rate	9600
Data Bits	8
Parity	None
<b>Language</b>	English



**Adobe PostScript**

Adobe, PostScript, Adobe Memory Booster and the PostScript Logo are registered trademarks of Adobe Systems Incorporated, which may be registered in certain jurisdictions. AppleTalk is a trademark of Apple Computer Inc.

## 4.8.05 Demo Page Print

---

### 4.8.05 Demo Page Print

The Demo Page provides a sample of the capabilities of the printer.

To perform the Demo Page Print, follow this procedure.

- Power ON the printer and wait for it to go ON-LINE.
  - Press ON-LINE to take the printer OFF-LINE.
  - Press NEXT / + for 3 seconds.
  - The Demo Page will be printed in approximately five seconds.
  - Once printing is complete, the printer will be OFF-LINE.
  - Press ON-LINE to place the printer ON-LINE.
-

# Demo Page Sample: OL400E

Demo Page sample: OL400e

Demo Page: OL400e

## **OL400e**

### L E D P a g e P r i n t e r

The **OL400e** allows you to print your business documents quickly and quietly. Since the **OL400e** has **HP® LaserJet® IIp+** compatibility, you have instant access to a very large base of business applications. Standard resident bitmap fonts and **USPS POSTNET Bar Codes** support your applications. **HP LaserJet IIp+**, **OL400**, and **USPS POSTNET** fonts including **HP A, B, C, F, L, P, Y,** and **S1** cartridge compatibility are provided.

#### **OL400e Resident Fonts**

Courier

**Courier Bold**

*Courier Italic*

Courier

**Courier Bold**

*Courier Italic*

Line Printer

**OL400 Swiss™ Bold**

OL400 Dutch™ Roman

*OL400 Dutch Italic*

**OL400 Dutch Bold**

OL400 Dutch Roman

**USPS POSTNET Bar Codes**



The many standard features of the **OL400e**, combined with its expandability, support your present and future needs.

#### **OL400e Standard Features**

HP LaserJet IIp+ Emulation

4 pages per minute print speed

512 Kilobytes Memory

RISC based Microprocessor for improved performance

100 sheet Letter/A4/Universal Paper Cassette

\*Free\* paper size for custom size paper

Parallel and RS-232-C Serial Interfaces

Large receive buffer for fast data transfer

Automatic Interface Switching for easy sharing

Graphics Compression for Full Page Business Graphics

USPS POSTNET Bar Code fonts

USPS POSTNET Check Digit calculation

Function to disable Operator Panel

Function to download messages to LCD Display

Power Saving Silent Standby at 15 Watts

#### **OL400e Optional Equipment**

100 sheet Legal/Universal Paper Cassettes

Up to 4 Megabytes Optional Memory

Library of Font and Macro Cards

The powerful RISC based microprocessor of the **OL400e** ensures fast printing of complex documents. The very small footprint and quiet operation are a welcome addition to any desk. When in \*Power Save\* standby, it is actually silent. \*Free\* paper size allows printing on custom size paper. Up to 4 Megabytes optional memory enhance graphics printing and DLL font capacity. The **OL400e** gives you the clear advantage.

HP and LaserJet are registered trademarks of Hewlett-Packard Company. Swiss and Dutch are trademarks of Bitstream, Inc.





## Demo Page Sample: OL410E

---

Demo Page sample: OL410e

# OL410e LED PagePrinter

The **OL410e** prints your business documents quickly and quietly. With **HP® LaserJet® III** compatibility, you have instant access to a large base of business applications. **OL410e's** **OKI600** mode printing provides superior print quality for text and graphics. **OL410e** resident fonts include 8 HP LaserJet III Scalable fonts plus Scalable Courier, Line Printer and USPS POSTNET fonts.

Optional Font Cards with **AGFA Intellifont®** Fonts, and the **AGFA Typeface Library**, ensure that your typeface needs are met.

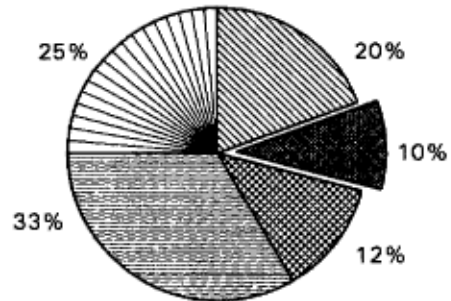

### VECTOR GRAPHICS

The powerful RISC based microprocessor and internal Font Cache of the **OL410e** ensure fast printing of complex documents at 4 pages per minute. The small footprint and **Energy Star™** silent-standby operation are a welcome addition to any desk. Automatic Interface Switching allows easy printer sharing. "Free" paper size allows printing on custom size paper stock. Options include memory expansion to 5MB, a 250 sheet Second Paper Tray, a Multi-Sheet Feeder for up to 50 envelopes, and Letter/Universal and Legal/Universal Paper Cassettes.

The **OL410e** gives you the clear advantage.

<b>OL410e Fonts</b>	<b>12 scalable fonts by AGFA</b>
	CG Times
	<i>CG Times Italic</i>
	<b>CG Times Bold</b>
	<i>CG Times Bold Italic</i>
	Univers®
	<i>Univers Italic</i>
	<b>Univers Bold</b>
	<i>Univers Bold Italic</i>
	Courier
	<i>Courier Italic</i>
	<b>Courier Bold</b>
<i>Courier Bold Italic</i>	
Line Printer (bitmap)	
USPS POSTNET Bar Codes	
	

HP and LaserJet are registered trademarks of Hewlett-Packard Company. Energy Star is a trademark of the United States Environmental Protection Agency. Intellifont is a registered trademark of AGFA Division, Miles Inc. Univers is a registered trademark of Linotype AG and/or its subsidiaries.

# Demo Page Sample: OL410E-PS

Demo Page sample: OL410e-PS

Demo Page: OL410e/PS

# OL410e/PS



**Adobe PostScript**

Adobe PostScript™ Level 2 and  
HP® LaserJet® III emulations.



Powerful RISC microprocessor  
for ultra fast performance.



600 DPI Class output  
for superior print quality.



Parallel, serial and AppleTalk™  
interfaces for both PC and MAC users.



Reliable LED print head  
for assured quality and long life.

Adobe, PostScript and the PostScript Logo are registered trademarks of Adobe Systems Incorporated, which may be registered in certain jurisdictions.  
AppleTalk is a trademark of Apple Computer Inc.  
HP and LaserJet are Registered trademarks of Hewlett-Packard Company



## 4.9 Resistance Check Points - Registration Motor, Drum Motor, And Fusing Unit

### 4.9 RESISTANCE CHECK POINTS - Registration Motor, Drum Motor, and Fusing Unit

#### Registration Motor, Drum Motor, and Fusing Unit

The diagram below shows the pins used to verify the resistance of the registration motor, drum motor, and fusing unit. Use this diagram to assist you when troubleshooting.

Unit	Circuit Diagram	Illustration	Resistance
Registration Motor	<p>1 → Orange 2 → Yellow 3 → Brown 4 → Black</p>		<p>Between pins 1 and 2: 32 Ω</p> <p>Between pins 3 and 4: 32 Ω</p>
Drum Motor	<p>1 → Orange 2 → Yellow 3 → Brown 4 → Black</p>		<p>Between pins 1 and 2: 32 Ω</p> <p>Between pins 3 and 4: 32 Ω</p>
Fusing Unit	<p>1 → Thermostat 2 → Heater 3 → Thermistor 4 → Thermistor</p>		<p>Between pins 1 and 2: 0 to 3Ω</p> <p>Between pins 3 and 4: 220KΩ (at room temperature)</p>

## 4.9.02 Resistance Check Points - Transformer And Fan Motor

### 4.9.02 Transformer and Fan Motor

The following diagram shows the pins used to verify the resistance of the transformer and the fan motor. Use this diagram to assist you when troubleshooting.

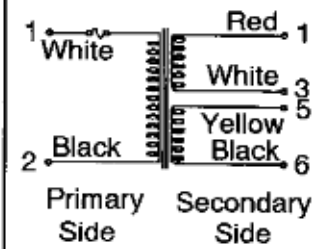
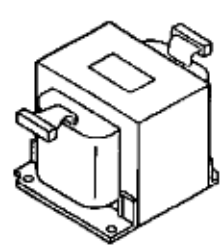
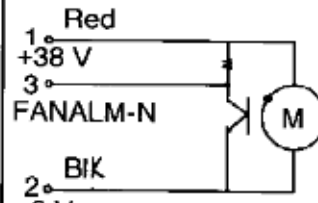
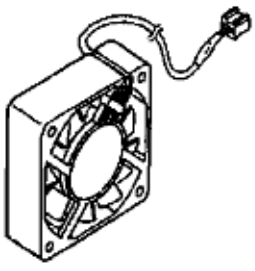
Unit	Circuit Diagram	Illustration	Resistance
Transformer	 <p>1 White 2 Black Primary Side</p> <p>Red 1 White 3 Yellow 5 Black 6 Secondary Side</p>		<p><u>Primary Side</u></p> <p>Between pins 1 and 2: 14.9Ω</p> <p><u>Secondary Side</u></p> <p>Between pins 1 and 3: 1.3Ω</p> <p>Between pins 5 and 6: 1.1Ω</p>
Fan	 <p>1 Red +38 V 3 FANALM-N</p> <p>2 Blk 0 V</p> <p>M</p>		<p>Between pins 1 and 2: ≈670Ω</p> <p>Between pins 1 and 3: ≈0Ω</p> <p>Between pins 2 and 3: ≈0Ω</p>

# Appendix A

## A.1 Board Diagrams & General Information

### A.1 BOARD DIAGRAMS & General Information

#### General Information

This section describes the characteristics of the printed circuit boards used in the printers.

The following areas are covered.

- Function
- Firmware
- Fuses
- Jumpers
- Sensors
- Switches
- Test Points







Where an item is not applicable, the word NONE will be listed.



## A.2 Index To Charts

---

### A.2 INDEX TO CHARTS

Description	Board Designation	Product	Section
Main Controller Board	OLCW	OL400e	A.2.01 (  )
Main Controller Board	OLCW-13	OL410e	A.2.01 (  )
PostScript Board	OLPT	OL410e/PS	A.2.02 (  )
RAM Expansion Board	OLCB	OL400e/OL410e	A.2.03 (  )
Operator Panel Board	OLLC	All	A.2.04 (  )
Power Supply Board	OLAA	All	A.2.05 (  )

---

## A.2.01 Main Controller Board (OLCW)

---

### A.2.01 Main Controller Board (OLCW)

#### Function

The main controller board controls the data reception and page formatting functions. This board also controls the print engine and reports printer errors/status through the operator panel. The main control board in the OL410e contains 1 Mbyte of RAM.

#### Firmware

Q2: Program ROM - 512 K PROM. (OL410e - 1 M PROM) Stores the printer control program.

Q3: Font ROM - 512 K ROM. (OL410e - 512 K ROM) Stores the bit-mapped fonts.

Q9: EEPROM - 1 K x 1 bit EEPROM. Stores Menu Data, Counter Data, Print Intensity Values and Start of Print Position Value.

#### Fuses

NONE

#### Jumpers

SP1: CLOSED          Debug Mode (Factory Use Only)  
      OPEN            Normal Position  
      OPEN is the default position for SP1.

SP2: Not installed at this time

SP3: A SIDE          +5 vdc supplied to Pin 18 of Centronics Interface  
      B SIDE          +5 vdc is NOT supplied to Pin 18 of Centronics Interface  
      The A SIDE is the default position for SP3.

#### Sensors

NONE

#### Switches

NONE

#### Test Points

NONE

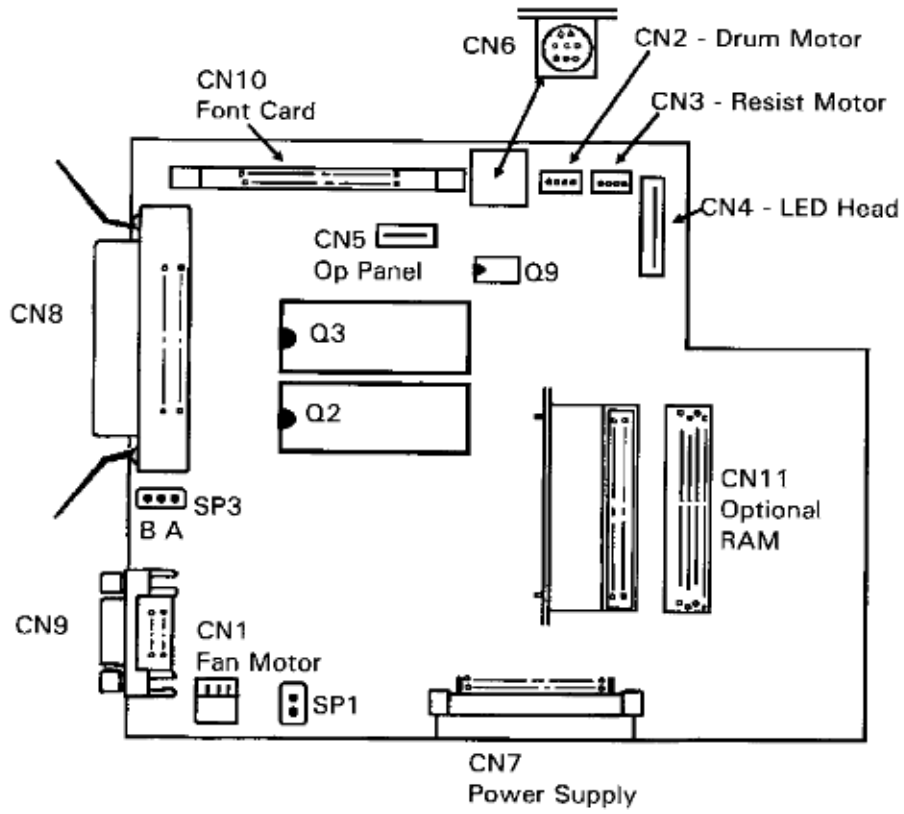

## A.2.02 Postscript Board (OLPT)

---

### A.2.02 PostScript Board (OLPT)

#### Function

The PostScript Board (OLPT) connects to the Main Control Board (OLCW-13) . The OLPT Board contains the Adobe PostScript Interpreter, the Type 1 PostScript Fonts and a RISC microprocessor. The OLPT board also contains 1 MByte of RAM as well as sockets for an additional 3 MByte of RAM. The LocalTalk interface port is located on the OLPT BOARD.

#### Firmware

03B: Adobe Type 1 Fonts PostScript Interpreter (1 M EPROM)

03C: Adobe PostScript Interpreter (1 M EPROM)

#### Fuses

NONE

#### Jumpers

NONE

#### Sensors

NONE

#### Switches

NONE

#### Test Points

NONE

#### Memory Expansion

(in addition to the 1 MB of RAM on the Main Control Board)

MEMOR Y	Q1	Q2	Q3	Q4	Q5	Q6	Q7	Q8
1 MB	OPEN	OPEN	OPEN	OPEN	OPEN	OPEN	Soldered	Soldered
2 MB	INSTALL	INSTALL	OPEN	OPEN	OPEN	OPEN	Soldered	Soldered
3 MB	INSTALL	INSTALL	INSTALL	INSTALL	OPEN	OPEN	Soldered	Soldered
4 MB	INSTALL	INSTALL	INSTALL	INSTALL	INSTALL	INSTALL	Soldered	Soldered

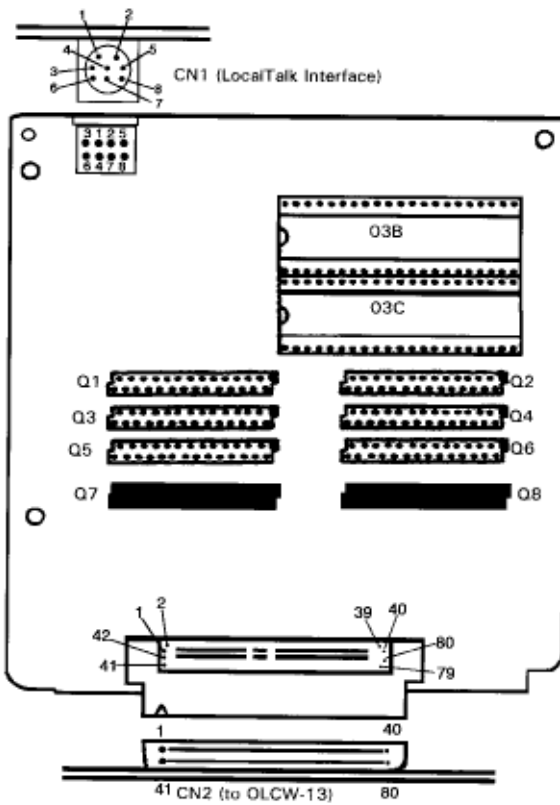

## A.2.03 Ram Expansion Board (OLCB)

---

### A.2.03 RAM Expansion Board (OLCB)

#### Function

The RAM expansion board increases the amount of RAM available to the microprocessor. This board has a capacity of up to 4 Mbyte of Dynamic RAM in 1 Mbyte increments.

#### Firmware

NONE

#### Fuses

NONE

#### Jumpers

SP1 - SP4: A SIDE 4 Mbit RAM in Locations Q7 / Q8  
SP5 - SP8: A SIDE 4 Mbit RAM in Locations Q9 / Q10  
SP9 - SP12: A SIDE 4 Mbit RAM in Locations Q11 / Q12  
SP13 - SP16: A SIDE 4 Mbit RAM in Locations Q13 / Q14  
These jumpers are set to the A SIDE at the factory.

#### Sensors

NONE

#### Switches

NONE

#### Test Points

NONE

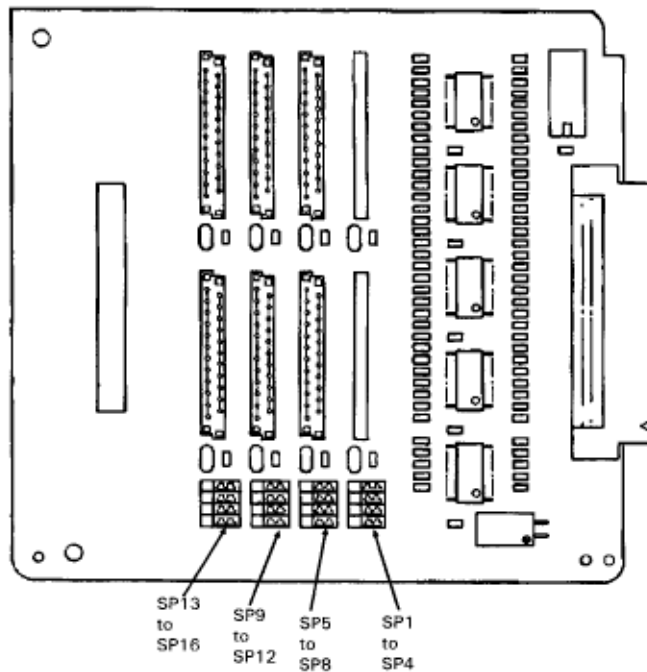

## A.2.04 Operator Panel Board

---

### A.2.04 Operator Panel Board

#### Function

The operator panel provides the operator with a means of controlling printer operation. This board is also used by the main controller board to report printer errors/status.

#### Firmware

NONE

#### Fuses

NONE

#### Jumpers

NONE

#### Sensors

NONE

#### Switches

SW1 through SW8: for a description of functions, refer to the User's Documentation.

#### Test Points

NONE

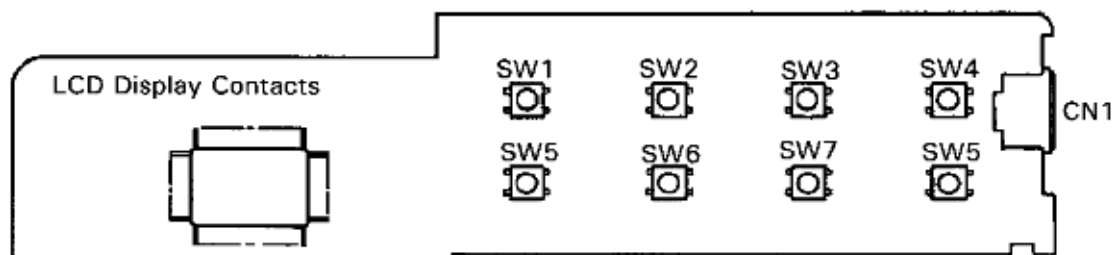

## A.2.05 Power Supply Board (OLAA)

---

### A.2.05 Power Supply Board (OLAA)

#### Function

The power supply board converts the AC Input Voltage into +38 vdc, +5 vdc, +8 vdc, and -8 vdc for use throughout the printer. The power supply board generates the high voltages required for electrostatic printing. The photosensors and cover open switch are located on this board.

#### Firmware

NONE

#### Fuses

F1:125 volt6.3 amp.	AC Line Fuse
F2:125 volt1.6 amp.	Protects the primary of the AC transformer
F3:125 volt3.15 amp.	Protects the +38 vdc and +5 vdc circuits

#### Jumpers

NONE

#### Sensors

Refer to Section 2 of this Service Handbook for more information on the sensor functions.

PS1:Paper Exit Sensor

PS2:Paper Sensor (detects the leading edge of the paper)

PS3:Inlet Sensor 1

PS4:Paper End Sensor (detects the presence of paper in the tray)

PS5:Inlet Sensor 2 (detects the paper width)

PS6:Toner Low Sensor

#### Switches

SW1:Power Switch

SW2:Cover Open Switch

Disables the +38 vdc and high voltage circuits when the cover is open.

#### Test Points

Refer to the Power Supply Board Illustration for test point locations.



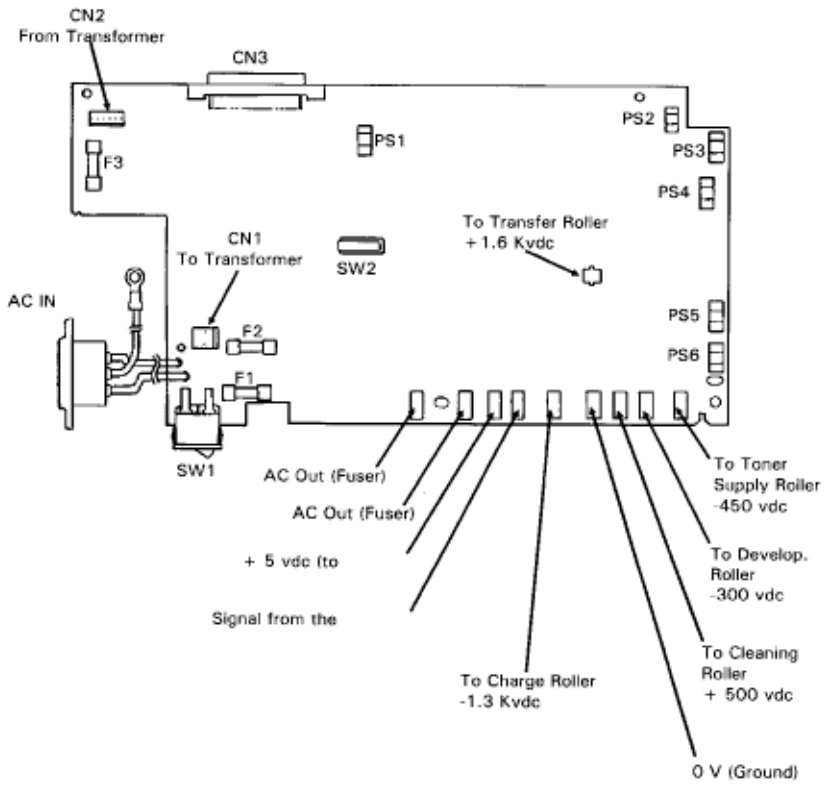

## \*\*A.3 Interconnect Diagram

### A.3 INTERCONNECT DIAGRAM

On the following diagram is the interconnect diagram for the printer.

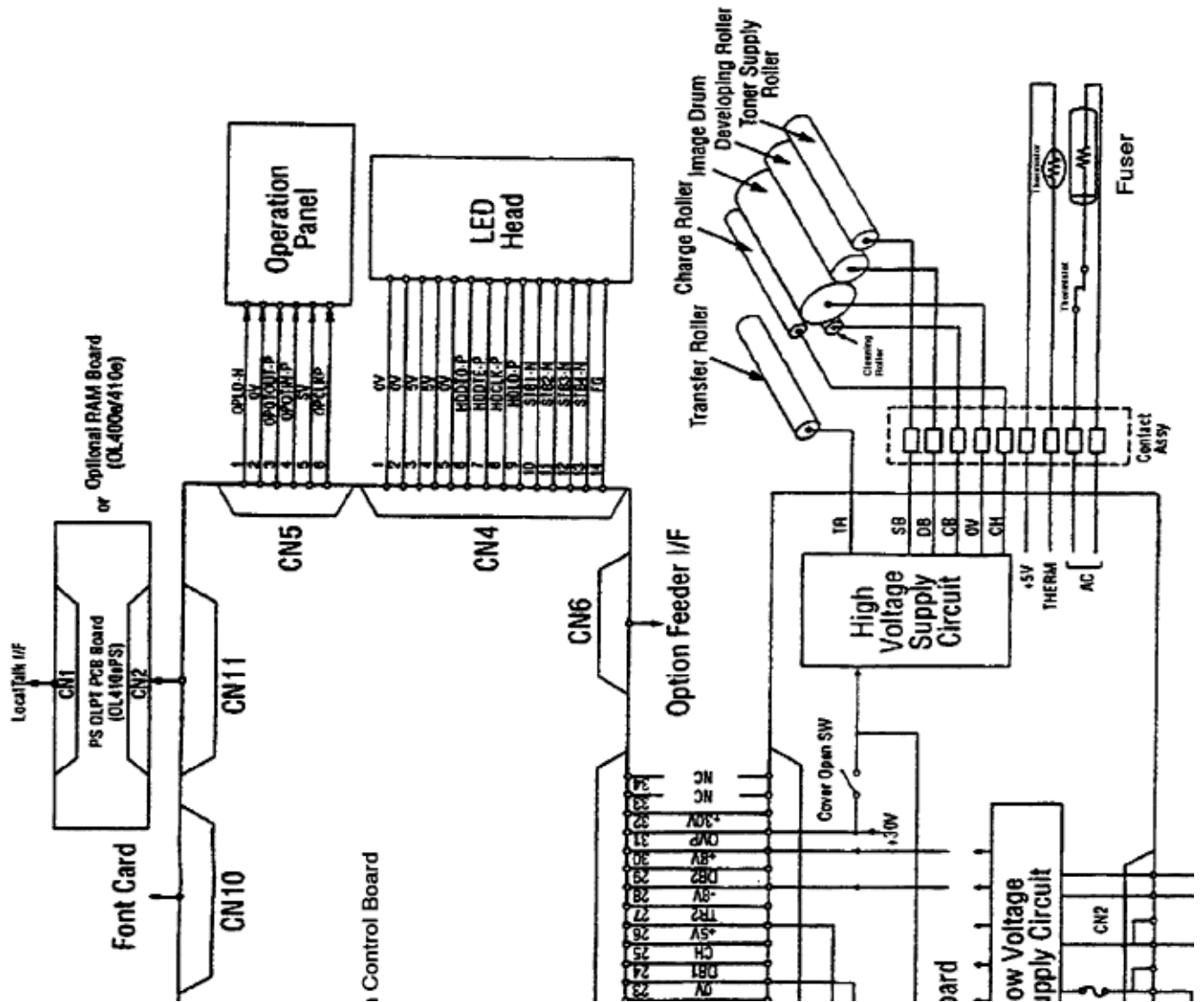

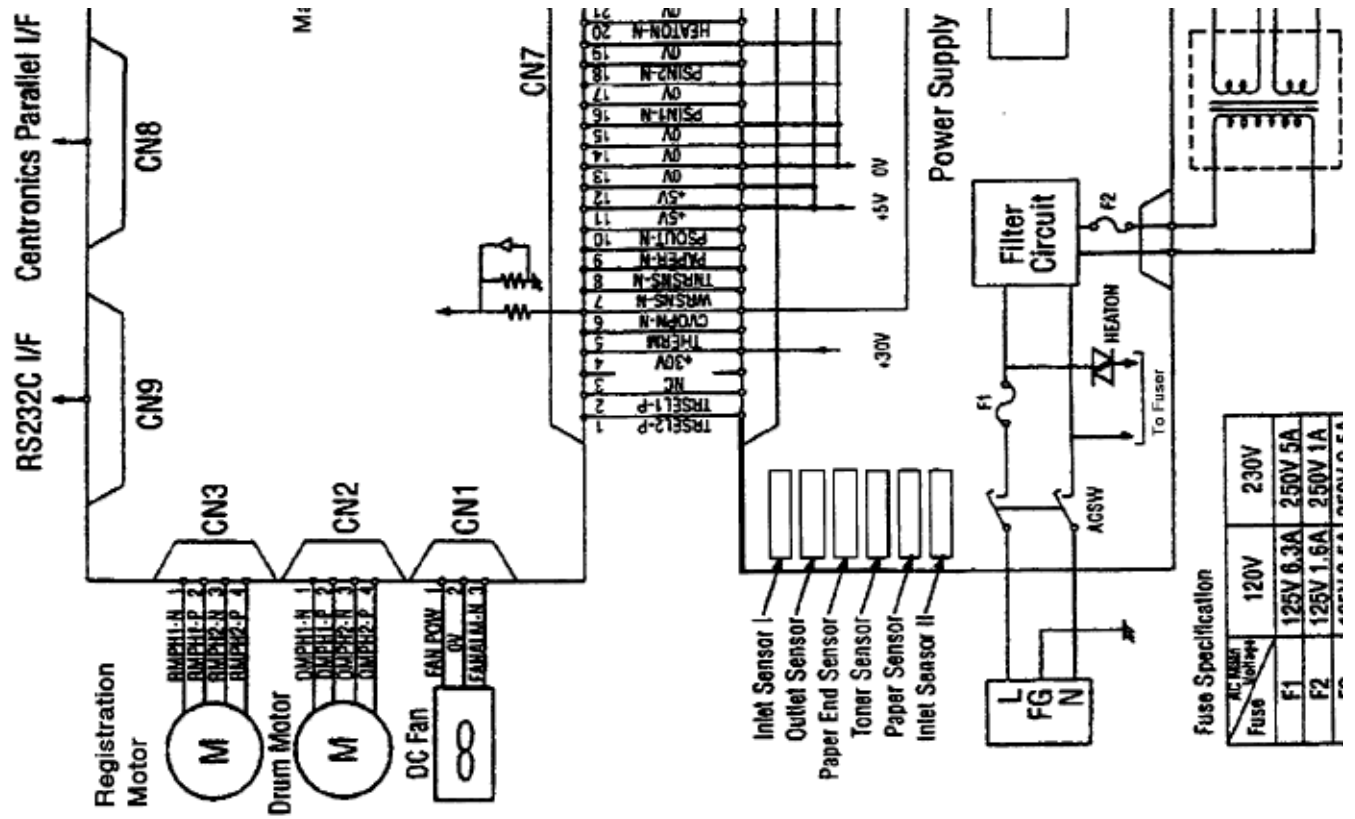

# Appendix B

## Illustrated Parts Listing - Overview & General Information

This appendix will assist you in identifying the assemblies and parts of the product.

Use Section Four (Failure Analysis (📄)) to determine the defective part(s).

Locate the part and its part number in this section.

Appendix B is cross-referenced to Section Three (Maintenance).

### Format

The format for this appendix is a series of tables with diagrams. The tables contain the item reference number, the Okidata and Oki-Japan (Oki-J) part numbers, the part description, a comments section, and the disassembly procedure.

Example:

Item	Okidata P/N Oki-J P/N	Description	Comments Refer to B.1.02	Disassembly Procedure
------	--------------------------	-------------	-----------------------------	--------------------------

Items with the comments RSPL (Recommended Spare Parts List), Consumable, Document, or Option are available from Okidata. Items without these comments are usually not stocked.

Some items are only available as assemblies. Every effort has been made to clearly indicate which items are in assemblies and which are not.

N/A will appear where a part number is not available.

Please refer to the RSPL, which can be found on Okidata's Bulletin Board (Okilink II), for current part numbers, prices, and recommended stocking levels for each item listed as a recommended spare part. For instructions on accessing Okilink II, refer to the Service Center Reference Guide.

Please read carefully the Definition of Terms in the following section. It is important that you understand the different types of classifications and their availability.

### REMEMBER

Current part numbers, recommended stocking levels, and pricing information are available through Okilink II. Refer to the Service Center Reference Guide for information on accessing Okilink II.

## **B.1.02 Definition Of Terms**

---

### **1.02 Definition of Terms**

#### **Assemblies**

Assemblies are parts grouped under a single description and/or part number. Generally, individual items in an assembly are not available from Okidata.

Assemblies are surrounded by broken line boxes in the diagrams.

Assemblies will say "Includes xx xx" under the Comments section of the tables.

Parts in assemblies will say "Part of xx" under the Comments section of the tables.

#### **Blank**

Okidata does not recommend stocking this item. This item should be purchased on an As Required Basis only.

The availability of this item is NOT guaranteed by Okidata.

#### **Consumable**

A consumable is a supply item which has a specified life and must be periodically replaced. It is purchased and installed by the end user. Okidata machines are designed to work exclusively with Okidata consumables. By using genuine Okidata consumable products, the investment made in the equipment is protected.

#### **Document**

A document is a printed item which supports the service and marketing of a product. Various documents are available from Okidata.

#### **Drivers**

Printer drivers are updated frequently. Please refer to Okilink II for the latest printer driver information.

#### **Firmware**

Firmware is revised frequently. Please refer to Okilink II for the latest firmware information.

#### **MPF**

This part is used in the Multi-Purpose Feeder Unit, one of the option items.

#### **Option**

An option is a part/assembly which is added to a product. The option expands the product's functionality. An option may or may not be installed by the end user. Instructions for installation accompany each option.

#### **Option RSPL**

Okidata recommends that this part/assembly be on hand for servicing installed options.

#### **RSPL**

Okidata recommends that this part/assembly be on hand for servicing.

**SPF**

This part is used in the Second Paper Feed Unit, one of the option items.

**Technical Service Bulletins**

Technical Service Bulletins (TSBs) are also referred to as Okidata's monthly mail.

The TSBs contain the latest information on firmware revisions, procedure changes, and technical information updates.

Okidata distributes the TSBs through Okilink II. The TSBs are issued monthly.

**400e**

This part is used exclusively by the OL400e LED Page Printer.

**410e**

This part is used exclusively by the OL410e LED Page Printer.

**410e-PS**

This part is used exclusively by the OL410e/PS LED Page Printer.

---

## **B.1.03 Parts Ordering Information**

---

### **B.1.03 Parts Ordering Information**

#### **Service Center Reference Guide**

When a technician has successfully completed a Service Training Course for a product and the Dealer has become Service Authorized, an information package is provided to the Dealer. The Okidata Service Center Reference Guide outlines the following items.

- Responsibilities of Okidata Service Centers
- Spare parts and consumables information
- Procedures for warranty repairs
- Product Training, Certification, and Authorization
- Product Support information
- Okidata Depot information and services
- Third Party Service information
- Information about Okidata's Customer Information Center
- Okidata Service and Support telephone numbers.

The Service Center Reference Guide contains the procedures to follow for ordering parts. Please read, understand, and follow these procedures. Service Authorization for a specific product must be obtained before a Dealer can submit warranty claims.

Direct questions regarding the Service Center Reference Guide to Okidata Dealer Service. Refer to the Service Center Reference Guide for information on contacting Okidata.

#### **Placing a Parts Order**

All authorized Okidata resellers may order spare parts and consumables for Okidata products. Orders are placed through Okidata's Logistics Department.

Please refer to your Service Center Reference Guide for details on ordering parts.

You should have the following information available before you place your order.

- Okidata Dealer Authorization Number
- Okidata Customer Number
- Your Purchase Order Number
- Okidata Part Number(s)

Use this Appendix, Okilink II, or contact Okidata Technical Support to find the correct part number. Refer to the Service Center Reference Guide for information on contacting Okidata.











---

## B.2 Listing Of Illustrated Parts Breakdown Charts

---

### B.2 CHARTS

Below is an index for the illustrated parts breakdown charts.

Description	Section
Lower Base Unit (1 of 2)	B.2.01 
Lower Base Unit (2 of 2)	B.2.02 
Upper Cover	B.2.03 
Base Unit (1 of 2)	B.2.04 
Base Unit (2 of 2)	B.2.05 
Options	B.2.06 
Multi-Purpose Feed Unit (Option)	B.2.07 
Second Paper Feed Unit (Option) [ST-250]	B.2.08 
Second Paper Feed Unit (Option) Cabinet [ST-250]	B.2.09 
Packaging	B.2.10 
Consumables	B.2.11 



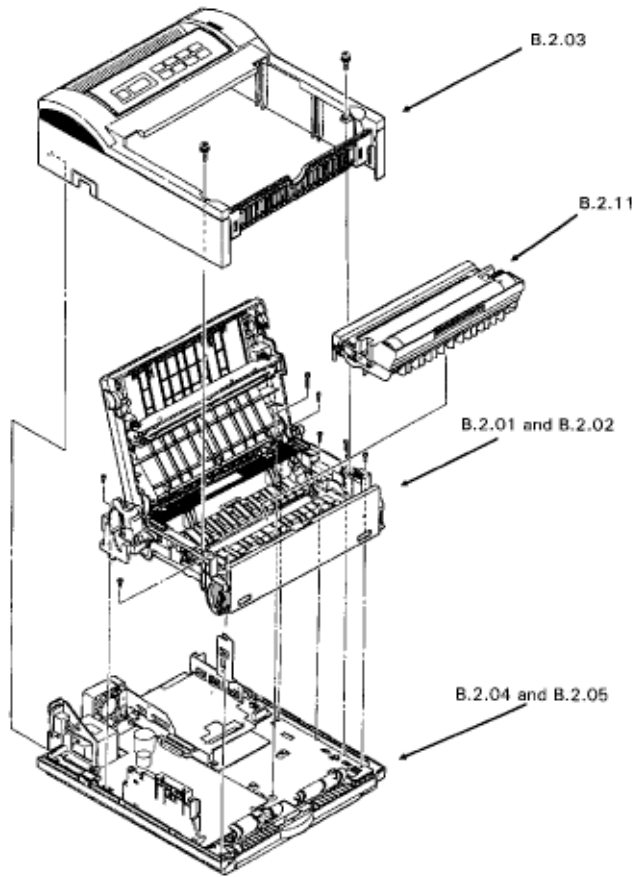

## B.2.01 Lower Base Unit (1 Of 2)

### B.2.01 Lower Base Unit (1 of 2)

Part numbers are subject to change. Refer to Okilink II for current part numbers and pricing information.

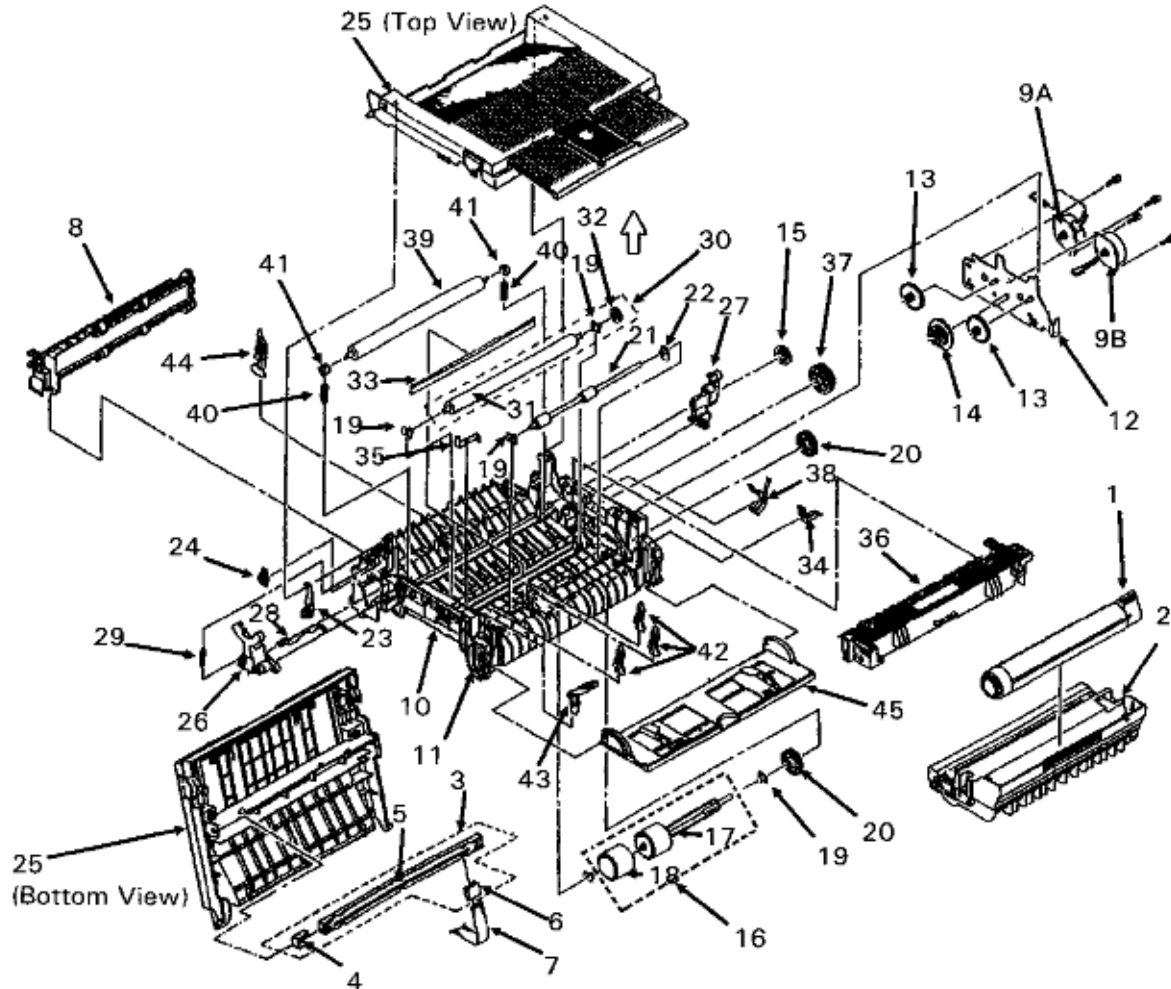

Item	Okidata P/N	Oki-J P/N	Description	Comments	DisassemblyPr
1	52107201	4YA4083-6400G2	Kit: Toner Cartridge	Consumable	3.2.01
2	56116801	4YA4083-6300G2	Kit: Image Drum	Consumable	3.2.01
3	56111201	3YX4083-6245G1	Assembly: LED Head	RSPLInc. 4 5 6	3.2.07
4	51014601	4PP4083-6173P1	Contact: Ground Clip LED Head	RSPLPart of 3	3.2.07
5	55624101	4YA4116-1104G1	Unit: LED Head	Part of 3	3.2.07
6	56730201	22A1286P0140	Connector: PC	RSPLPart of 3	3.2.07
7	56629001	4YX4121-1025G2	Cable: Flexible (LED Head)	RSPL	3.2.07
8	53342801	2PA4083-6120G1	Roller: Eject (Assembly)	RSPL	3.2.08
9 A	56510701	4PB4083-6075P1	Motor: Stepper (Main)	RSPL	3.2.09
9 B	56510701	4PB4083-6075P1	Motor: Stepper (Registration)	RSPL	3.2.10
10	50217601	2PP4083-6801G1	Frame: Lower Base (Assembly)	RSPL	3.2.11
11	51014101		Plate: FG		3.2.11
12	N/A	N/A	Motor: Bracket		3.2.12
13	51225701	4PP4083-2593P1	Gear: Stepper Motor Idle	RSPL	3.2.12
14	51229301	3PP4083-6076P1	Gear: Reduction	RSPL	3.2.12
15	51229201	4PP4083-6081P1	Gear: Eject Roller Idle	RSPL	3.2.12
16	51112601	3PA4083-6019G1	Shaft: Hopping Roller Assembly	RSPL Inc.17 18	3.2.13

17			Shaft: Hopping Roller	Part of 16	3.2.13
18	53342401	4PB4083-6021P1	Hopping Roller Rubber	Part of 16	3.2.13
19	51607402	4PP4083-6022P2	Bearing	RSPLPart of 30	3.2.13 15 16
20	51228901	4PB4083-6024P1	Gear: Hopping Roller Clutch	RSPL	3.2.13 15
21	53342501	3PB4083-6030P1	Roller: Registration	RSPL	3.2.15
22	51607501	4PP4083-6031P1	Bearing: Registration Roller	RSPL	3.2.15

See Section B.2.02 ( ) Lower Base Unit (2 of 2) for part numbers 23 - 45.

---

## B.2.02 Lower Base Unit (2 Of 2)

### B.2.02 Lower Base Unit (2 of 2)

Part numbers are subject to change. Refer to Okilink II for current part numbers and pricing information.

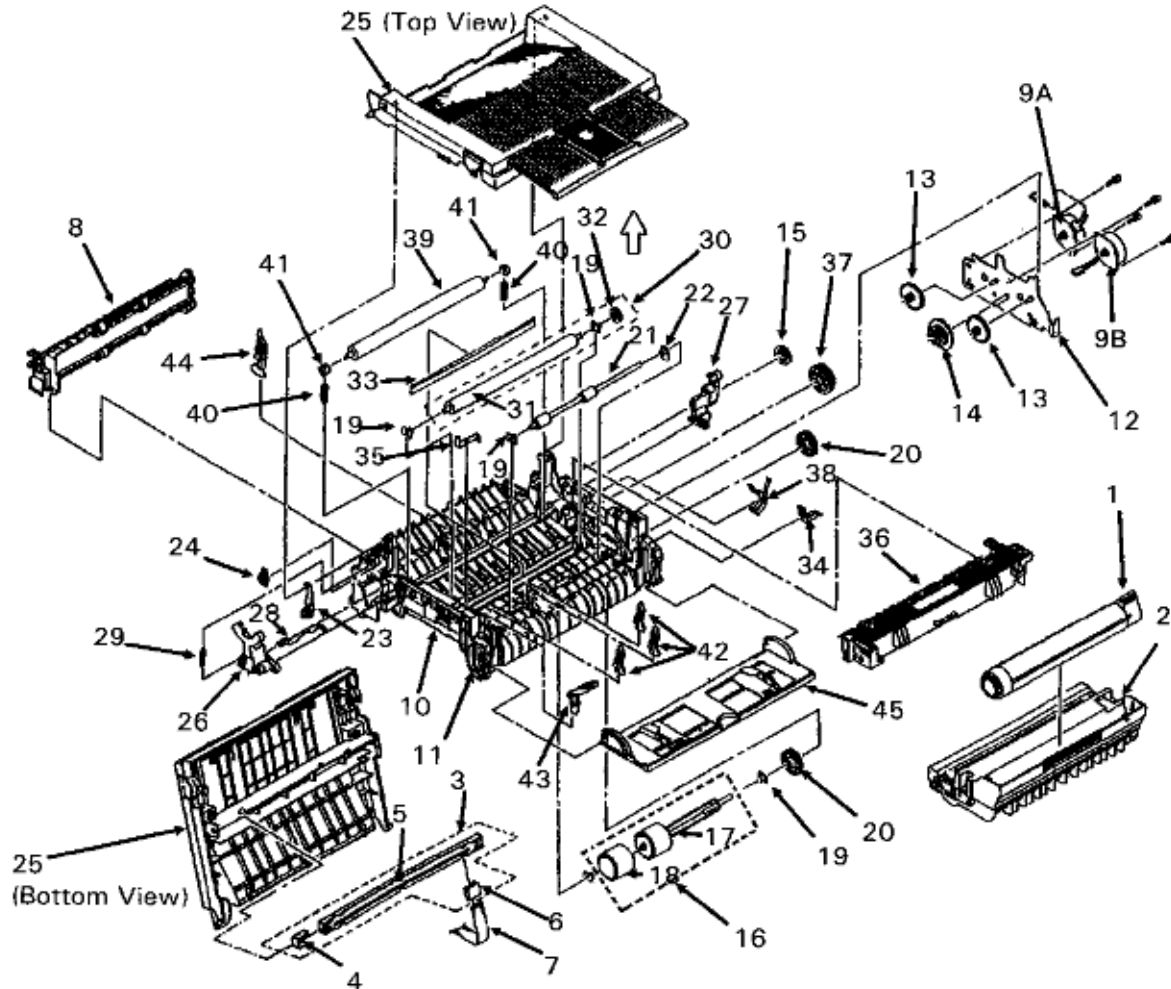

Item	Okidata P/N	Oki-J P/N	Description	Comments	DisassemblyPr
23	53069101	4PP4083-6191G1	Arm: Stacker Cover Damper	RSPL	3.2.14
24	51229401	4PB4083-6197P1	Gear: Stacker Cover Damper	RSPL	3.2.14
25	53069001	2PA4083-6160G1	Assembly: Face Down Stacker Cvr	RSPL	3.2.14
26	50805801	3PP4083-6053P1	Lever: Reset (L)	RSPL	3.2.14
27	50805901	3PP4083-6054P1	Lever: Reset (R)	RSPL	3.2.14
28	53068901	3PP4083-6058P1	Arm: Cover Open	RSPL	3.2.14
29	50924201	4PP4083-6057P1	Spring: Stacker Cover Reset	RSPL	3.2.14
19	51607402	4PP4083-6022P2	Bearing	RSPLPart of 30	3.2.13 15 16
30	53347001	3PA4083-6246G1	Roller: Transfer Assy	RSPLInc. 19 31 32	3.2.16
31	53342601	4YB4083-6040P1	Roller: Transfer	RSPLPart of 30	3.2.16
32	51229001	4PP4083-6042P1	Gear: Transfer Roller	Part of 30	3.2.16
33	51010903	4PB4083-3182P3	Strip: Anti-Static	RSPL	3.2.16
34	N/A	N/A	Transfer Roller Ground Plate		3.2.16
35	N/A	N/A	N/A Ground Plate		3.2.16
36	50217501	2YX4083-6100G1	Unit: Fuser 120 V (Assembly)	RSPL	3.2.17
36	50217502	2YX4083-6100G2	Assembly: Fusing Unit 230 V	Option RSPL	3.2.17
37	51229101	4PP4083-6080P1	Gear: Fuser Roller Idle	RSPL	3.2.17
38	N/A	N/A	Fuser Frame Ground Plate		3.2.17

39	53343701	3PB4083-6064P1	Roller: Backup (Pressure Roller)	RSPL	3.2.18
40	50925301	4PP4083-6065P1	Spring: Bias	RSPL410e	3.2.18
41	51607601	4PP4083-6052P1	Bushing: Pressure Roller	RSPL	3.2.18
42	51010701	4PP4083-6083P1	Plate: Sensor (Inlet)	RSPL	3.2.19
43	50405501	4PP4083-6086P1	Sensor: Toner	RSPL	3.2.20
44	51010801	4PP4083-6085P1	Plate: Sensor (Outlet)		3.2.21
44	51010802	4PA4083-6025P1	Lever: Exit Sensor (Assy)	RSPL	3.2.21
45	51011001	2PA4083-6130G1	Guide: Manual Feed (Assembly)	RSPL	3.2.22

See Section B.2.01 ( ) Lower Base Unit (1 of 2) for part numbers 1 - 22.

---

## B.2.03 Upper Cover

### B.2.03 Upper Cover

Part numbers are subject to change. Refer to Okilink II for current part numbers and pricing information.

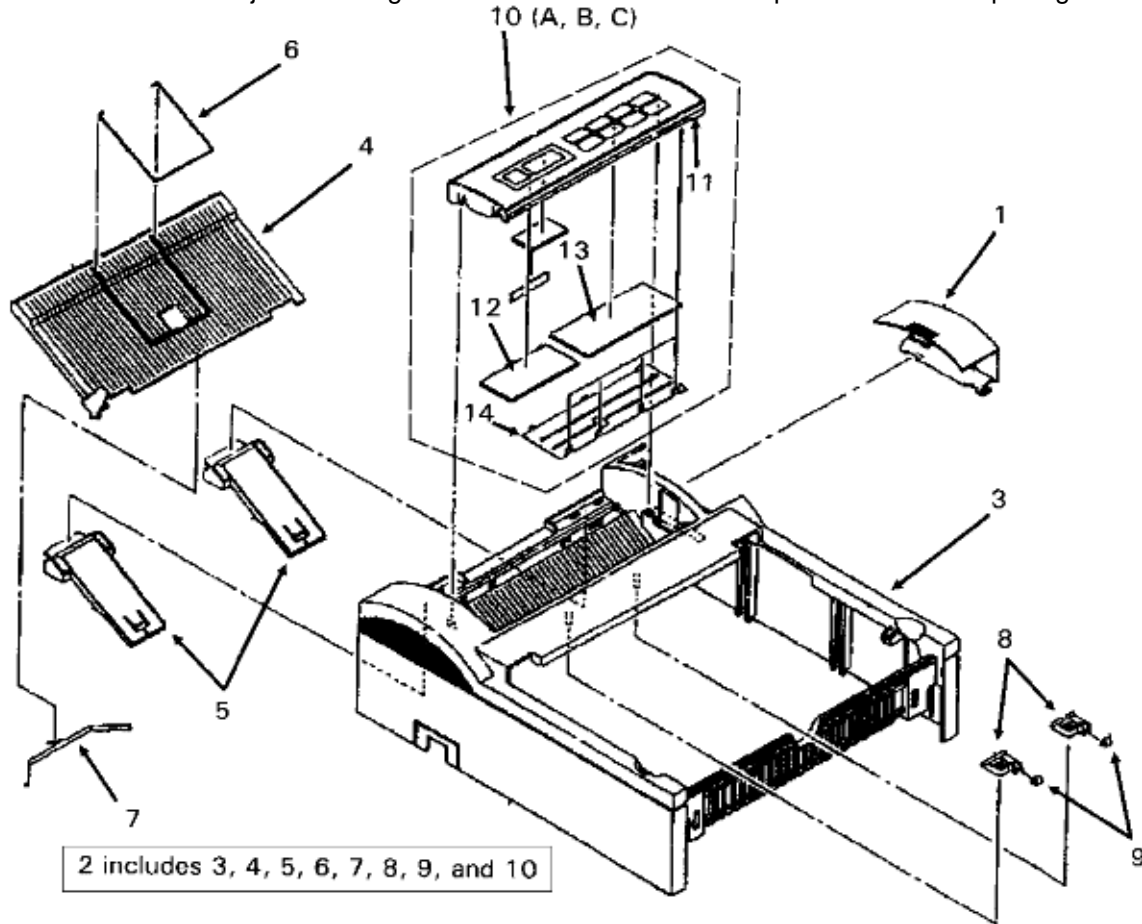

2 includes 3, 4, 5, 6, 7, 8, 9, and 10

Item	Okidata P/N	Oki-J P/N	Description	Comments	Disassembly Pr
1	53069301	2PP4094-7815P1	Cover: IC Card	RSPL	3.2.03
2	53069201	1PP4094-7813P1	Assm: Upper Cvr Inc. 3 4 5 6 7 8 9 10		3.2.02
3	53070301	2PP4083-6808G1	Cover: Upper	RSPL	3.2.02
4	50101301	1PP4094-7814P1	Assembly: Face-Up Stacker	RSPL	3.2.04
5	50708001	3PP4094-7816P1	Clamp: Stacker	RSPL	3.2.04
6	N/A	N/A	Face-Up Wire Guide		3.2.04
7	N/A	N/A	Retention Spring		;
8	50924301	4PP4083-6180P1	Spring: Bias	RSPL400e	3.2.05
9	53502401	4PP4083-2024P1	Roller Exit	RSPL	3.2.05
10A	50101401	3PP4083-6804G1	Assembly: Op Panel (400e)	RSPL 400eInc 11 12 13 14	;
10B	50101404	4YA4083-6804G4	Assembly: Op Panel (410e)	RSPL 410eInc 11 12 13 14	;
10C	50101411	4YA4083-6804G11	Assembly: Op Panel (410e PS)	RSPL 410e PSInc 11 12 13 14	;
11A	52070601	3PB4083-6176P1	Touch Sheet: Op Panel (OL400e)	RSPL 400ePart of 10	;
11B	52070602	3PB4083-6177P1	Touch Sheet: Op Panel	RSPL 410ePart of 10	3.2.06
12	53069401	2PP4083-6172P1	Cover: Op Panel	Part of 10	;
13	53342901	4PB4083-6235P1	Insulator: LCD	Part of 10	3.2.06
14	55624202	653A0049M0002	LCD: Element FRD-11442	Part of 10	;

## B.2.04 Base Unit (1 Of 2)

### B.2.04 Base Unit (1 of 2)

Part numbers are subject to change. Refer to Okilink II for current part numbers and pricing information.

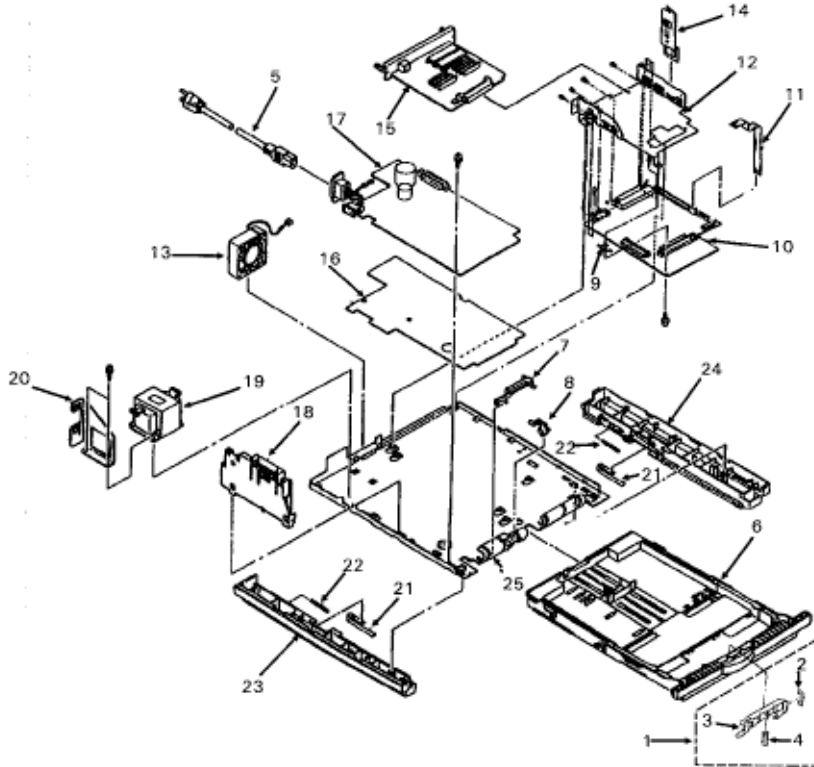

Item	Okidata P/N	Oki-J P/N	Description	Comments
1	53345601	3PP4083-5663G1	Frame: Separation Assembly	RSPLInc. 2 3 xx
2	50926901	4PP4083-6228P1	Spring: Anti-Vibration	Part of 1
3	51014401	3PP4083-5207P1	Frame: Separation	Part of 1
4	50927801	4PP4083-6209P1	Spring: Cassette Separator	Part of 1
5	56609701	3YS4011-1315P1	Cord: AC 120 V	RSPL
5	56624301	3YS4011-1266P1	Cord: AC 220 V	Option RSPL
6	50217701	1PA4083-6200G1	Cassette: Paper Cassette Assm	RSPL
7	51011501	3PP4083-6154P1	Plate: Cassette Sensor	RSPL
8	51011401	4PP4083-6082P1	Plate: Paper Supply Sensor	RSPL
9	51011601	4PP4083-6137P1	Plate: Earth	RSPL
10A	55072711	4YA4121-1007G11	PCB: OLCW-11 (w/o ROM) (Main Controller Board)	RSPL40
10B	55072713	4YA4121-1007G13	PCB: OLCW-13 (w/o ROM) (Main Controller Board)	RSPL41
10C	55077811	4YA4121-1022G11	PCB: OLPT w/o ROM - PostScript	RSPL410e PS
11	56627901	238A1071P0003	Cord: Flexible (Op Panel)	RSPL
12	51013901	2PP4083-6141P1	Plate: Board Guide	RSPL
13	56510801	270A2165P0001	Fan	RSPL
14	51014001	4PP4083-6138P1	Guide: Cable	RSPL
15	55938301		IC: EEPROM BR93LC46A	RSPL410e

## B.2.05 Base Unit (2 Of 2)

### B.2.05 Base Unit (2 of 2)

Part numbers are subject to change. Refer to Okilink II for current part numbers and pricing information.

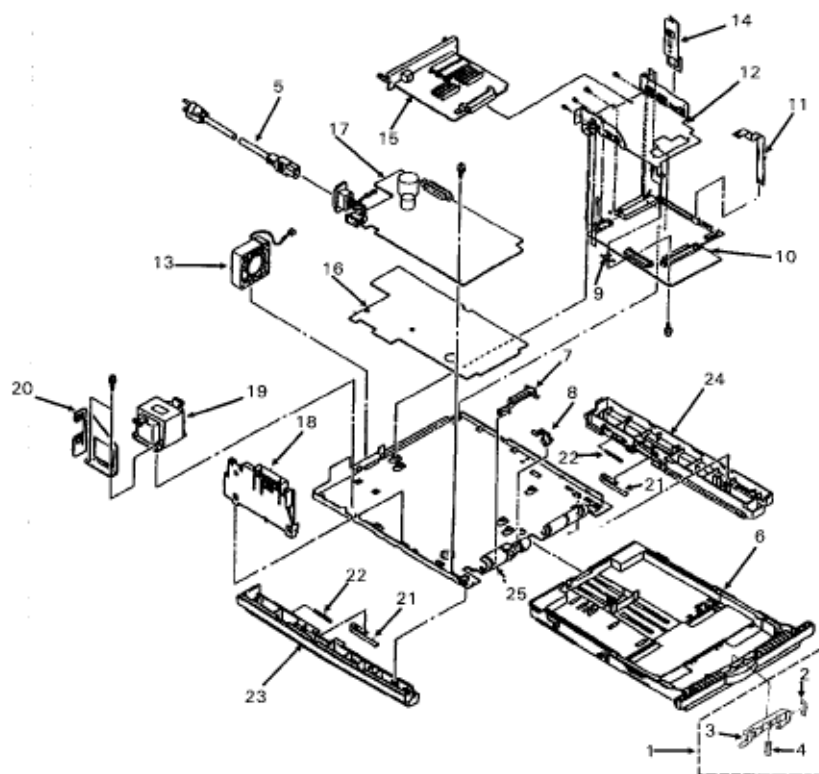

Item	Okidata P/N	Oki-J P/N	Description	Comments	DisassemblyPr
16	51709401	3PB4083-6144P1	Insulator	RSPL	3.2.25
17	56412601	4YB4049-1776P1	Power Supply 120 V (OLAA)	RSPL	3.2.25
17	56412701	4YB4049-1777P001	Power Supply 230 V (OL400e)	Option RSPL400e	3.2.25
18	56730001	3PA4083-6090G1	Assembly: Contact	RSPL	3.2.25
19	56412801	4YB4049-7032P1	Transformer 120 V	RSPL	3.2.26
19	56412901	4YB4049-7033P1	Transformer 230 V (OL400e)	Option RSPL	3.2.26
20	50516301	4PP4083-6145P1	Holder: Inlet	RSPL	3.2.26
21	50924501	4PP4083-6153P1	Spring: Support	RSPL410e	3.2.27
22	50924401	4PP4083-6152P1	Spring: Cassette Eject	RSPL	3.2.27
23	51011201	3PP4083-6802G1	Guide: Cassette (L)	RSPL	3.2.27
24	51011301	3PP4083-6803G1	Guide: Cassette (R)	RSPL	3.2.28
25	51011101	1PP4083-6140P1	Plate: Base	RSPL	3.2.29



## B.2.06 Options

### B.2.06 Options

Part numbers are subject to change. Refer to Okilink II for current part numbers and pricing information.

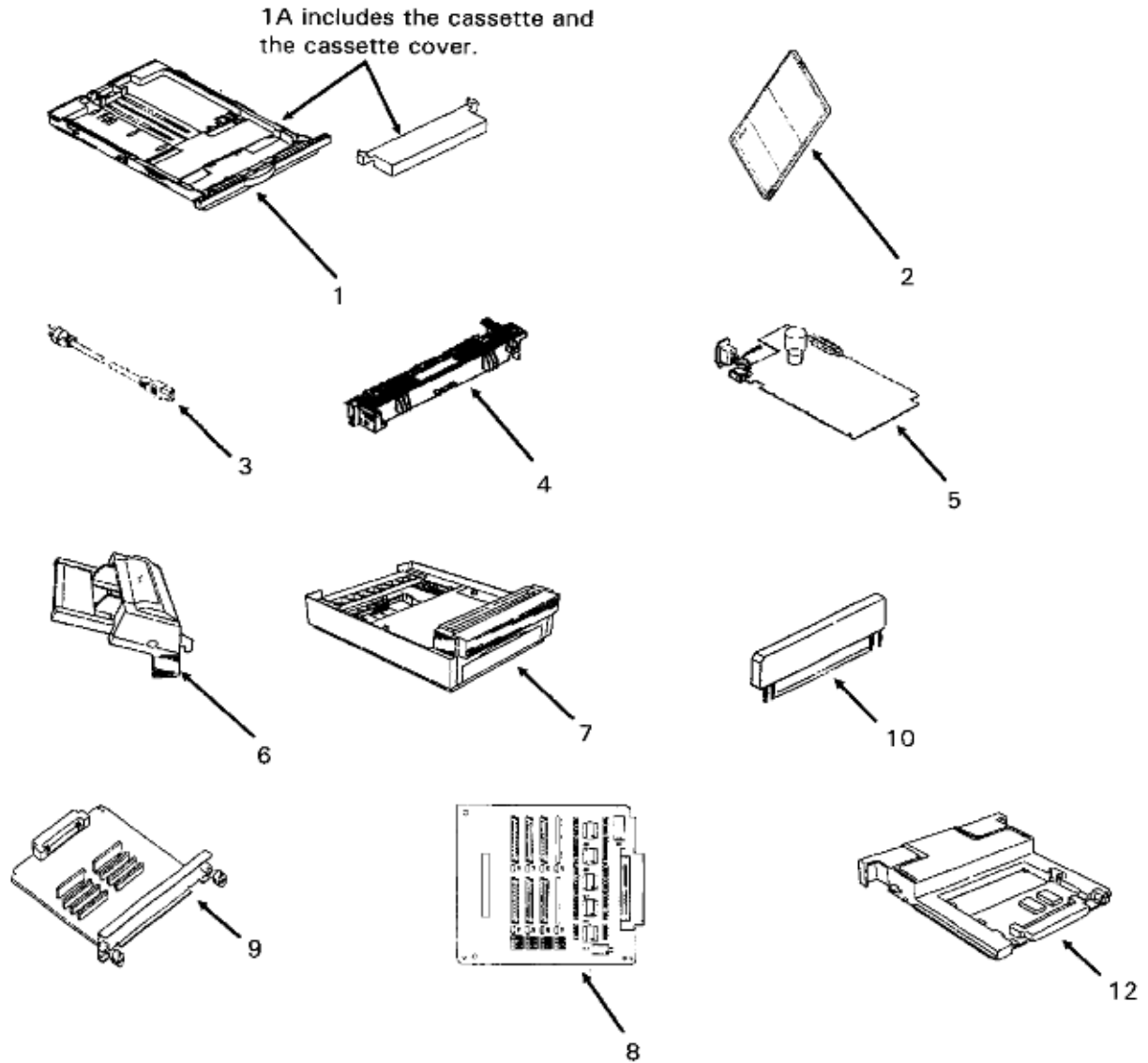

Item	Okidata P/N	Oki-J P/N	Description	Comments	Disasse
1	70024301	N/A	Tray: Letter (100 Sheet)	Option	3.2.01
1	70024401	N/A	Tray: Legal (100 Sheet)	Option	3.2.01
1A	70025201	N/A	Tray: Legal / Universal (250 Sheet)	Option	3.2.01
2	70026201	N/A	Kit: Font Card - Barcodes Plus II	Option	:
2	70026301	N/A	Kit: Font Card - Tax II	Option	3.2.01
2	70026401	N/A	Kit: Font Card - Micro Docs II	Option	3.2.01
2	70026501	N/A	Kit: Font Card - Oki PRO II	Option	3.2.01
3	56624301	3YS4011-1266P1	Cord: AC 220 V	Option RSPL	3.2.01
3	56624501	3YS4011-1270P1	Cord: AC 240 V (OL Series) UK	Option RSPL410e	:
4	50217502	2YX4083-6100G2	Assembly: Fusing Unit 230 V	Option RSPL	3.2.17
5	56412701	4YB4049-1777P001	Power Supply 230 V (OL400e)	Option RSPL400e	:
6	70025101	4YA4083-5500G2	Multi-Purpose Feed Unit	Option	:
7	70024501	4YA4083-5600G2	Second Paper Feed UnitST-250	Option	3.2.36

8	70024701	N/A	Kit: 1MB Memory Expansion	Option	N/A
9	55072811	4YA4121-1002G11	PCB: OLCB (RAM) OL400e	Option RSPL400e	I
10	55938701	4YA4121-1008G1	IC: RAM 1 MB (OL400e)	Option RSPL	I
10	70025701	N/A	1 MB Memory Chip Set	Option	N/A
11	56729901	Adapter (DB-9 to DB-25) (Serial Adapter) OL400e		Option RSPL	I
12	55075601	4YA4121-1031G001	PCB: 1 MB RAM (Non-Expandable)	RSPL410e	N/A

---

## B.2.07 Multi-Purpose Feeder Unit

### B.2.07 Multi-Purpose Feeder Unit

Part numbers are subject to change. Refer to Okilink II for current part numbers and pricing information.

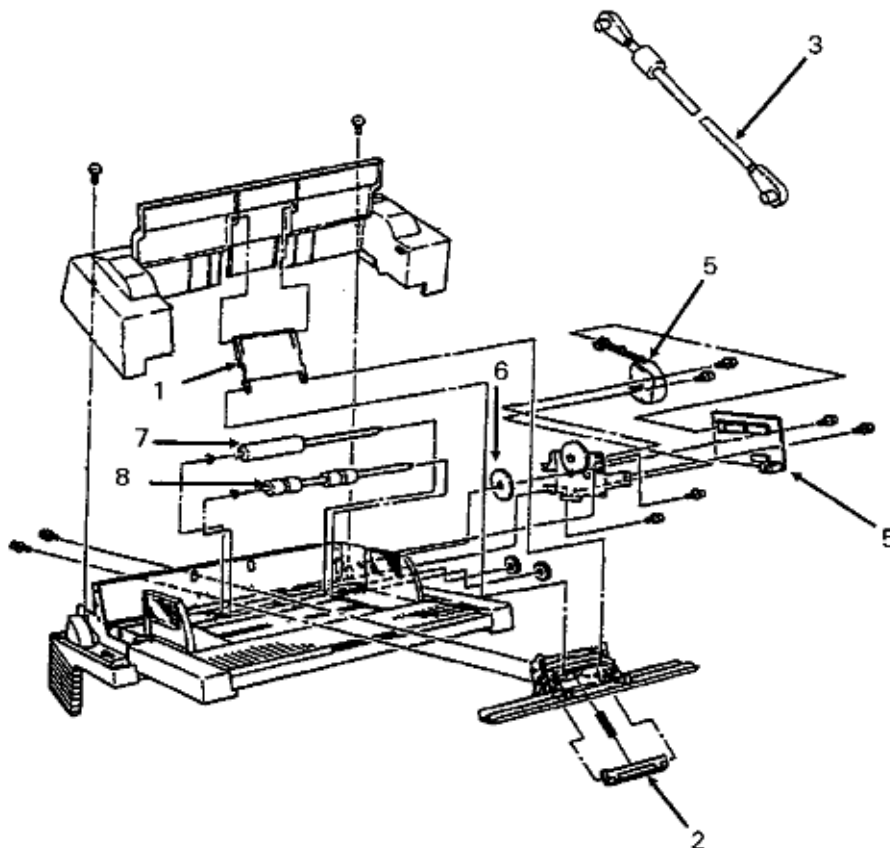

Item	Okidata P/N	Oki-J P/N	Description	Comments	DisassemblyPr
1	53344101	3PP4083-5540P1	Link	Option RSPLMPF	3.2.30
2	53344201	4PP4083-5544G1	Separator	Option RSPLMPF	3.2.31
3	56631203	3YS4011-3141P3	Cord: Connection (MS Feeder)	Option RSPLMPF	3.2.31
4	55074811	4YA4121-1014G11	PCB: OLEV-11 (Multi-Feeder)	Option RSPLMPF	3.2.32
5	56510701	4PB4083-6075P1	Motor: Stepper (MPF)	Option RSPLMPF	3.2.33
6	51229601	4PP4083-5520P1	Gear: Planet	Option RSPLMPF	3.2.34
7	53343801	3PB4083-5514P1	Roller: A	Option RSPLMPF	3.2.35
8	53343901	3PB4083-5524P1	Roller: Feed (B)	Option RSPLMPF	3.2.35

## B.2.08 Second Paper Feed Unit (Option) [ST-250]

### B.2.08 Second Paper Feed Unit (Option) [ST-250]

Part numbers are subject to change. Refer to Okilink II for current part numbers and pricing information.

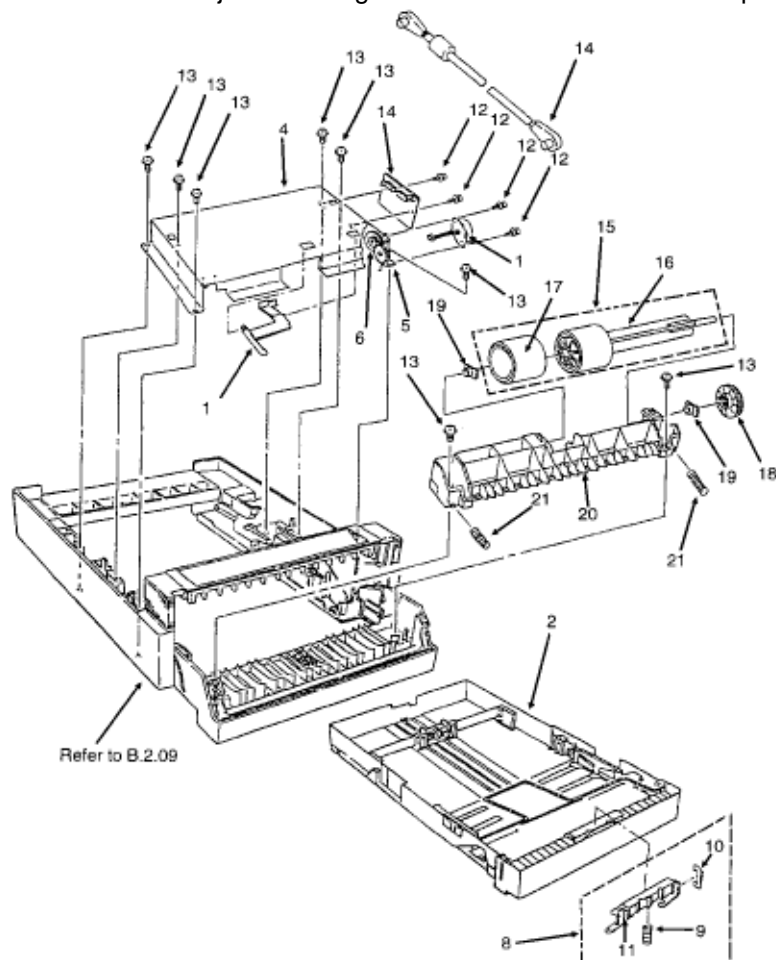

Item	Okidata P/N	Oki-J P/N	Description	Comments	Disasse
1	56510701	4PB4083-6075P1	Motor: Stepper (SPF)	RSPL	3.2.36
2		1PA4083-5640G1	Cassette: Universal	SPF	3.2.36
2	50218002	4YA4083-6270G10	Cassette: Paper	Option RSPLSPF	:
3	56631103	3YS4011-3140P3	Cord: Connection (Second Tray)	Option RSPLSPF	:
4		3PP4083-5617G1	Bracket: Motor	SPF	3.2.36
5		4PP4083-5622P1	Gear: Idle	SPF	3.2.36
6		4PP4083-2280P1	Gear: Idle (C)	Option RSPLSPF	3.2.36
7		2PP4083-5636P1	Lever: Paper End Sensor	SPF	:
8	53345601	3PP4083-5663G1	Frame: Separation Assembly	SPF Inc. 9 10 11	:
9	50927801	4PP4083-6209P1	Spring: Cassette Separator	Option RSPL SPF	Part of 8 :
10	50926901	4PP4083-6228P1	Spring: Anti-Vibration	Option RSPL SPF	Part of 8 :
11	51014401	3PP4083-5207P1	Frame: Separation	SPF	Part of 8 3.2.36
12		4PB4013-3100P2	Screw: Tapping (S-Tight)	SPF	:
13		4PB4083-5670P2	Screw: Tapping	SPF	3.2.36 3
14	55074812	4YA4121-1014G12	PCB: OLEV-12 (Second Tray)	Option RSPLSPF	3.2.37
15	51112601	3PA4083-6019G1	Shaft: Hopping Roller Assembly	RSPL Includes 16 17	3.2.38
16			Shaft: Hopping Roller	Part of 15	3.2.38
17	53342401	4PB4083-6021P1	Hopping Roller Rubber	Part of 15	3.2.38
18	51228901	4PB4083-6024P1	Gear: Hopping Roller Clutch	RSPL	3.2.38

19	51607402	4PP4083-6022P2	Bearing Option	RSPLSPF	3.2.38
20		1PP4083-5605	Frame: Hopping Roller	SPF	3.2.38
21		4PB4083-5665P1	Spring	SPF	3.2.38

---

## B.2.09 Second Paper Feed Unit (Option) Cabinet [ST-250]

### B.2.09 Second Paper Feed Unit (Option) Cabinet [ST-250]

Part numbers are subject to change. Refer to Okilink II for current part numbers and pricing information.

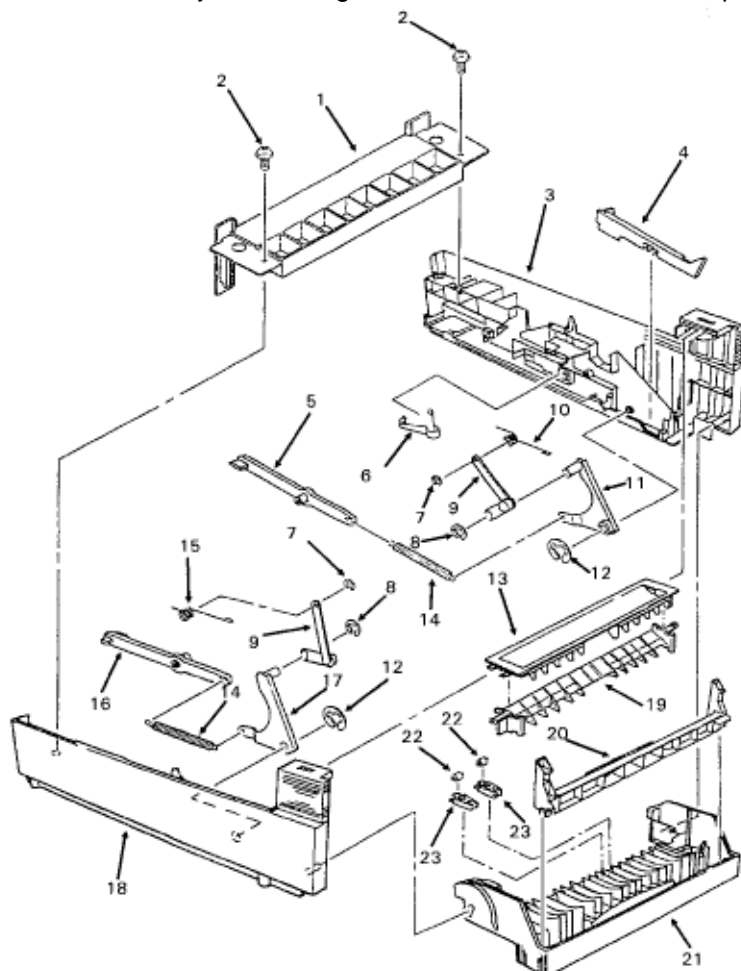

Item	Oki-J P/N	Description	Comments	Disassembly Procedure
1	1PP4083-5637P1	Frame: Rear Support	SPF	3.2.36
2	4BP4083-5670P2	Screw: Tapping	SPF	3.2.36
3	1PP4083-5611	Frame: Right Side	SPF	3.2.36
4	3PP4083-5615P1	Lever: Sensor	SPF	3.2.36
5	3PP4083-5613P1	Cam: Slide (R)	SPF	3.2.36
6	4PP4083-5655P1	Lever: Cassette Sensor	SPF	3.2.36
7	RE2-SK	E-Ring (Small)	SPF	3.2.36
8	RE5-SK	E-Ring (Medium)	SPF	3.2.36
9	4PP4083-5623G1	Arm: Lock	SPF	3.2.36
10	4PB4083-5660P1	Spring: Support (R)	SPF	3.2.36
11	4PP4083-5612G1	Lever: Plate Up (R)	SPF	3.2.36
12	RE7-SK	E-Ring (Large)	SPF	3.2.36
13	1PP4083-5653P1	Guide: Sheet (U)	SPF	3.2.36
14	4PB4083-5614P1	Spring: Plate Up	SPF	3.2.36
15	4PB4083-5661P1	Spring: Support (L)	SPF	3.2.36
16	3PP4083-5633P1	Cam: Slide (L)	SPF	3.2.36
17	4PP4083-5632G1	Lever: Plate Up (L)	SPF	3.2.36
18	1PP4083-5631P1	Frame: Left Side	SPF	3.2.36
19	1PP4083-5654P1	Guide: Sheet (L)	SPF	3.2.36

20	1PP4083-5606P1	Lever: Lock	SPF	3.2.36
21	1PP4083-5603P1	Cover: Front	SPF	3.2.36
22	4PP4083-5609P1	Roller: Bias	SPF	3.2.36
23	4PP4083-5608P1	Spring: Bias	SPF	3.2.36

---

## B.2.10 Packaging

### B.2.10 Packaging

Part numbers are subject to change. Refer to Okilink II for current part numbers and pricing information.

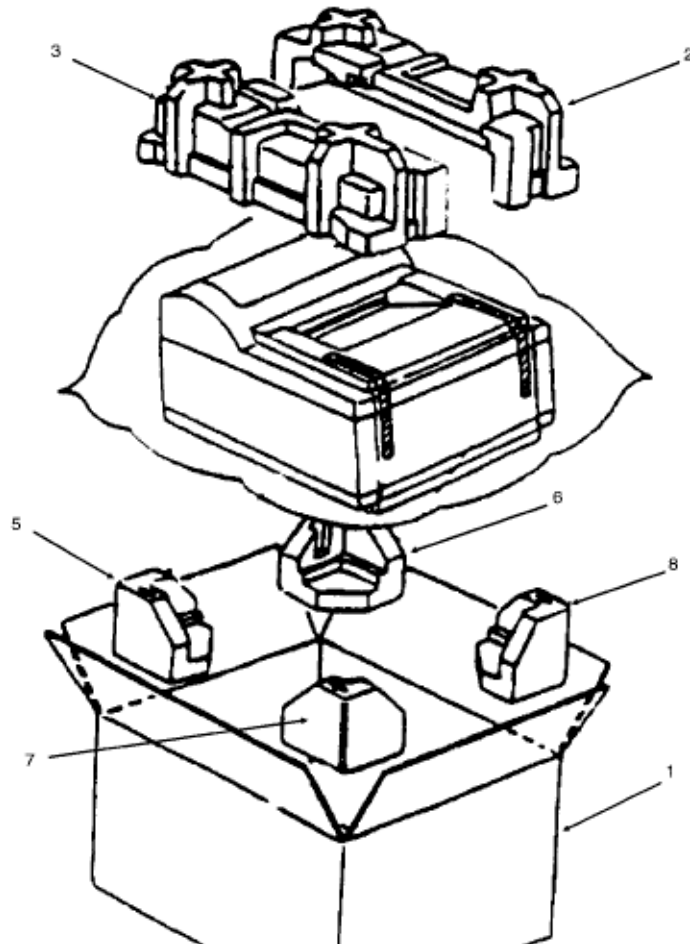

Item	Okidata P/N	Description	Comments
1	53573901	Box: Spares OL400e Series	RSPL
1A	53567503	Box: Graphics (OL400e) 400e	N/A
1B	53574001	Box: Graphics (OL410e) 410e	N/A
1C	53577801	Box: Graphics (OL410e PS)	410e-PS
1D	53575701	Box: Graphics Multilingual (OL400e)	400e
1E	53575801	Box: Graphics Multilingual (OL410e)	410e
1F	53577801	Box: Graphics Multilingual (OL410e/PS)	410e/PS
2	53569001	Foam: Packaging (Top Right) 3PP4083-6701P1	RSPL
3	53569002	Foam: Packaging (Top Left) 3PP4083-6701P2	RSPL
4	53571601	Foam: Packaging (Bottom) OL400e Series	RSPL Inc. 5 6 7 8
5	53569101	Foam: Packaging (Bottom Rear Left) 3PP4083-6702P1	Part of 4
6	53569102	Foam: Packaging (Bottom Rear Right) 3PP4083-6702	Part of 4
7	53569103	Foam: Packaging (Bottom Front Left) 3PP4083-6702P3	Part of 4
8	53569104	Foam: Packaging (Bottom Front Right) 3PP4083-6702P4	Part of 4
9	53569205	Sponge: EP Foam 4PP4083-3026P5	RSPL



## B.2.11 Consumables

---

### B.2.11 Consumables

Part numbers are subject to change. Refer to Okilink II for current part numbers and pricing information.

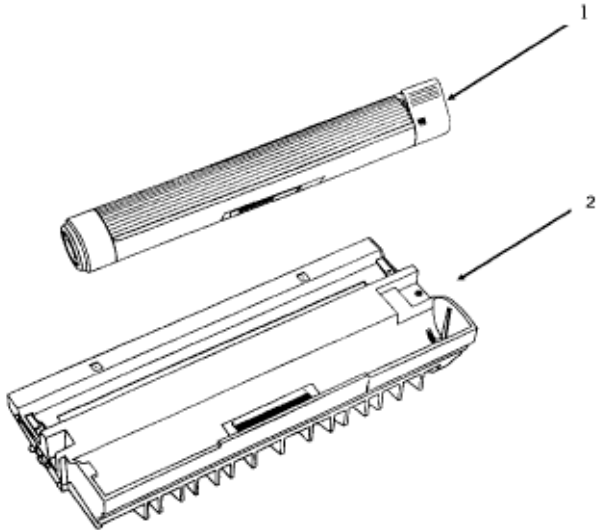

---

Item	Okidata P/N	Oki-J P/N	Description	Comments	Disassembly Procedure
1	52107201	4YA4083-6400G2	Kit: Toner Cartridge	Consumable	3.2.01
2	56116801	4YA4083-6300G2	Kit: Image Drum	Consumable	3.2.01

---